



THE ALEXANDER

AT ATHERSTONE COMMUNITY

THE ALEXANDER
 AT ATHERSTONE COMMUNITY
 ANGLIER, NORTH CAROLINA

SQUARE FOOTAGES

FIRST FLOOR (HTD.)	= 1506 sf
GARAGE	= 379 sf
FRONT PORCH	= 30 sf
TOTAL	= 1915 sf

INDEX OF SHEETS

A1.0	COVER SHEET
A1.1	GENERAL NOTES
A2.0	FLOOR PLAN & NOTES
A3.0	EXTERIOR ELEVATIONS & NOTES
A3.1	EXTERIOR ELEVATIONS
E1.0	FIRST FLOOR ELECTRICAL PLAN

INDEX OF SHEETS (CONT.)

CS1	COVER SHEET, SPECIFICATIONS, REVS.
CS2	COVER SHEET (CONTINUED)
S1.0m	MONO SLAB FOUNDATION
S3.0	FIRST FLOOR FRAMING PLAN
S7.0	FIRST FLOOR BRACING PLAN
D1-D7	STANDARD DETAILS

ENGINEER

SUMMIT ENGINEERING
 2520 WHITEHALL PARK DRIVE - SUITE 250
 CHARLOTTE, NC 28273
 704-504-1717

ARCHITECT

COX ARCHITECTURE & DESIGN, PLLC
 R. CRAIG COX
 1310 SOUTH TRYON STREET
 SUITE 111
 CHARLOTTE, NC 28203
 980-237-3827
 WWW.COXARCHITECTURE.COM
 CRAIG@COXARCHITECTURE.COM

GENERAL CONTRACTOR

LGI HOMES
 SCOTT STERLING
 V.P. OF CONSTRUCTION FOR MID-ATLANTIC
 704-953-3824

THESE DOCUMENTS ARE PROPERTY OF COX ARCHITECTURE AND DESIGN AND SHALL NOT BE USED OR REPRODUCED WITHOUT WRITTEN CONSENT BY COX ARCHITECTURE AND DESIGN. COX ARCHITECTURE AND DESIGN SHALL NOT BE LIABLE FOR ANY UNAUTHORIZED USE OF THESE DOCUMENTS.

PERMIT SET
 FOR CONSTRUCTION

● 29 DECEMBER 2021

COVER SHEET

A1.0



THE ALEXANDER

GENERAL NOTES

- DO NOT SCALE DRAWINGS; DESIGNATED DIMENSIONS SHALL BE USED IN PREFERENCE TO MEASUREMENTS BY SCALE.
- GENERAL CONTRACTOR SHALL VERIFY AND COMPLY TO ALL LOCAL & NATIONAL BUILDING CODES. CONTACT ARCHITECT IF INSPECTORS REQUIRE REVISIONS OR ALTERATIONS TO DRAWINGS.
- ALL SUB-CONTRACTORS SHALL BE RESPONSIBLE FOR DAMAGE TO OTHER TRADES.

DESIGN SPECIFICATIONS

- USE GROUP: (IBC 310)
 - "R-3" ONE & TWO FAMILY DWELLING
- CONSTRUCTION CLASS: (IBC 601)
 - "TYPE V-B" UNPROTECTED
- HEIGHT & AREA LIMIT: (LOCAL ZONING)
 - 35' MAXIMUM 2 STORY HEIGHT
- EMERGENCY ESCAPE: (IRC 310-311)
 - EGRESS OR RESCUE WINDOWS FROM SLEEPING ROOMS SHALL HAVE MINIMUM OF 4.0 SQ. FT. NET CLEAR OPENING.
 - MINIMUM 20" WIDTH.
 - MINIMUM 22" HEIGHT.
 - MAXIMUM 44" SILL HEIGHT
- GARAGE / HOUSE CEILING / ASSEMBLY: (IRC 702)
 - 1/2" GYPSUM WALL BOARD
 - 5/8" TYPE "X" GYPSUM BOARD CEILING WHERE LIVING IS ABOVE
 - 20 MINUTE RATED GARAGE / HOUSE DOOR
- ATTIC VENTILATION: (IRC 806)
 - 1915 TOTAL SF / [300] = 6.38 SQ. FT. AREA REQUIRED
 - RIDGE VENT:
 - 59 FT RIDGE VENT X [18 SQUARE INCHES IN FREE AREA] / [12] = 88.5 SQ. FT. PROVIDED
 - SOFFIT VENT:
 - 56 FT VENTED SOFFIT X [7 SQUARE INCHES IN FREE AREA] / 12 = 32.67 SQ. FT. PROVIDED

THESE DOCUMENTS ARE PROPERTY OF CDK ARCHITECTURE AND DESIGN AND SHALL NOT BE USED OR REPRODUCED WITHOUT WRITTEN CONSENT BY CDK ARCHITECTURE AND DESIGN. CDK ARCHITECTURE AND DESIGN SHALL NOT BE LIABLE FOR ANY UNAUTHORIZED USE OF THESE DOCUMENTS.

PERMIT SET FOR CONSTRUCTION

● 29 DECEMBER 2021

GENERAL NOTES

A1.1



THE ALEXANDER

THESE DOCUMENTS ARE PROPERTY OF CDX ARCHITECTURE AND DESIGN AND SHALL NOT BE USED OR REPRODUCED WITHOUT WRITTEN CONSENT. CDX ARCHITECTURE AND DESIGN SHALL NOT BE LIABLE FOR ANY UNAUTHORIZED USE OF THESE DOCUMENTS.

PERMIT SET FOR CONSTRUCTION

29 DECEMBER 2021

FLOOR PLAN

A2.0

FLOOR PLAN NOTES

-CONTRACTORS TO FIELD VERIFY ALL DIMENSIONS & NOTIFY ARCHITECT OF ANY DISCREPANCIES, ERRORS OR OMISSIONS PRIOR TO EXECUTION OF WORK.

-CLEANUP TO OCCUR DAILY.

-G.C. TO VERIFY FINISH GRADE @ HOUSE TO DETERMINE NUMBER OF STEPS.

-MECHANICAL CONTRACTOR TO COORDINATE W/ ARCHITECT LOCATION OF MAIN TRUNK & DISTRIBUTION LINES, REGISTERS (CENTER ALL REGISTERS ON WINDOWS), THERMOSTATS, AIR HANDLER & CONDENSERS.

-CEILING HEIGHTS LISTED ARE DIMENSIONED TO FRAMING (TOP OF SUBFLOOR TO UNDERSIDE OF FRAMING ABOVE)

-CONCRETE SLABS & SETTING BEDS TO ACCOMMODATE FOR ADEQUATE WATER DRAINAGE AT GARAGES AND PORCHES

-ATTIC ACCESS DROP-DOWN STAIRS TO CONFORM WITH LOCAL AUTHORITIES BASED ON IRC (R807.1) MINIMUM NET CLEAR OPENING OF 20" x 30". ALL ATTIC ACCESS STAIRS TO BE WEATHER STRIPPED & SEALED WITH R-VALUES THAT CONFORM WITH LOCAL AUTHORITIES BASED ON IRC (N1102.2.4). GC TO PROVIDE & INSTALL INSULATION DAMS TO RESTRICT TYPICAL ATTIC INSULATION FROM FALLING THROUGH ATTIC ACCESS OPENING. RIGID FOAM BOX COVER TO BE INSTALLED & SEALED AROUND FRAMING OF OPENING, NOT TO IMPEDE OR OBSTRUCT PERFORMANCE OF ADJACENT TYPICAL ATTIC INSULATION.

-HOSE BIBB(S) TO BE LOCATED 24" ABOVE FIRST FLOOR FINISHED FLOOR

WINDOW NOTES

-ALL WINDOW DIMENSIONS ARE BASED ON M.I. WINDOW ROUGH OPENING CALL OUTS, UNO. FINAL SELECTION OF WINDOW SIZES ARE TO BE VERIFIED IN FIELD.

-WINDOWS TO BE INSTALLED BY CERTIFIED WINDOW INSTALLER PER MANUFACTURER'S INSTALLATION INSTRUCTIONS.

-WINDOW SUPPLIER TO SPECIFY & ORDER TEMPERED GLASS IN WINDOWS AS REQ'D BY LOCAL CODE.

-G.C. AND WINDOW SUPPLIER TO VERIFY THAT EACH BEDROOM TO HAVE A MINIMUM OF ONE WINDOW WHICH MEETS EMERGENCY EGRESS AS REQUIRED BY LOCAL AUTHORITIES BASED ON IRC 2018. WINDOW SUPPLIER TO ADD EGRESS HARDWARE TO CASEMENT WINDOWS IF NECESSARY.

-TOP OF INTERIOR CASING @ ADJACENT DOORS & WINDOWS TO ALIGN WHEN HEADER CALL OUTS ARE EQUAL

DOOR NOTES

-ATTIC ACCESS DOORS TO INCLUDE WEATHER STRIPPING & INSULATION

-TOP OF INTERIOR CASING @ ADJACENT DOORS & WINDOWS TO ALIGN WHEN HEADER CALL OUTS ARE EQUAL

-DOOR SUPPLIER TO SPECIFY & ORDER TEMPERED GLASS IN DOORS AS REQ'D BY LOCAL CODE.

DOOR & WINDOW LEGEND

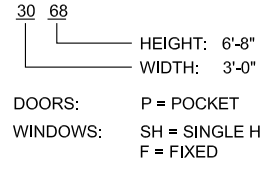

INSULATION NOTES

INSULATION VALUES PER 2009 SC ECC CH. 3 & 4 ENERGY CONSERVATION CODE

COLUMBIA, SC
RICHLAND COUNTY - CLIMATE ZONE 3A

TABLE 402.1.1

CEILING: R-30
FLOOR: R-19
WALL: R-13

SQUARE FOOTAGES

FIRST FLOOR (HTD.)	= 1506 sf
GARAGE	= 379 sf
FRONT PORCH	= 30 sf
TOTAL	= 1915 sf

FLOOR PLAN LEGEND

5S	5 SHELVES
1R 2S	1 ROD, 2 SHELVES
2R 2S	2 ROD, 2 SHELVES
HR	HANGING ROD
CO	CASED OPENING
W D	WASHER, DRYER
D/W	DISH WASHER
FRIG	REFRIGERATOR
LS	LAZY SUSAN
M	MIRROR
▲	SHOWER HEAD
(RH)	RAIN HEAD
(T)	TEMPERED GLASS

WALL SCHEDULE

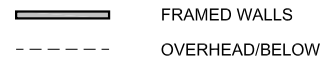

ALL WALLS ARE 2x4 WOOD STUD WALLS, UNO 5 1/2" DIMENSION INDICATES 2x6 WOOD STUD WALL

STAIR NOTES

-STAIR FABRICATOR / INSTALLER TO VERIFY THAT STAIRS MEET ALL REQ'D CODES

-ADJUSTMENTS TO STAIR TO BE CONFIRMED W/ ARCHITECT & CONTRACTOR PRIOR TO STAIR CONSTRUCTION

CEILING HEIGHT NOTES

8' - 1 1/2" CEILING HEIGHTS ON FIRST FLOOR

MEASURED FROM TOP OF SUBFLOOR / CONCRETE SLAB TO BOTTOM OF FLOOR JOISTS / ROOF TRUSSES

COLUMN NOTES

COLUMNS TO BE: AFCO OR COLUMN OF EQUAL BEARING CAPACITY. (6000 # MINIMUM)
TOP CONNECTION: (2) #8 - 1/4" x 3" STAINLESS STEEL SCREWS PER SIDE INSERTED INTO BEAM.
BOTTOM CONNECTION: (3) UBS - #18043 BRACKETS FASTENED WITH (2) 1/2" x 1 1/4" SCREWS INTO COLUMN & (2) 1/4" x 3 3/4" CONCRETE SCREWS THROUGH FASTENER INTO CONCRETE

ELECTRICAL PANEL/METER

MAXIMUM DISTANCE BETWEEN ELECTRICAL PANEL & ELECTRICAL METER (NEC 230.70) TO BE DETERMINED BY LOCAL AUTHORITY.

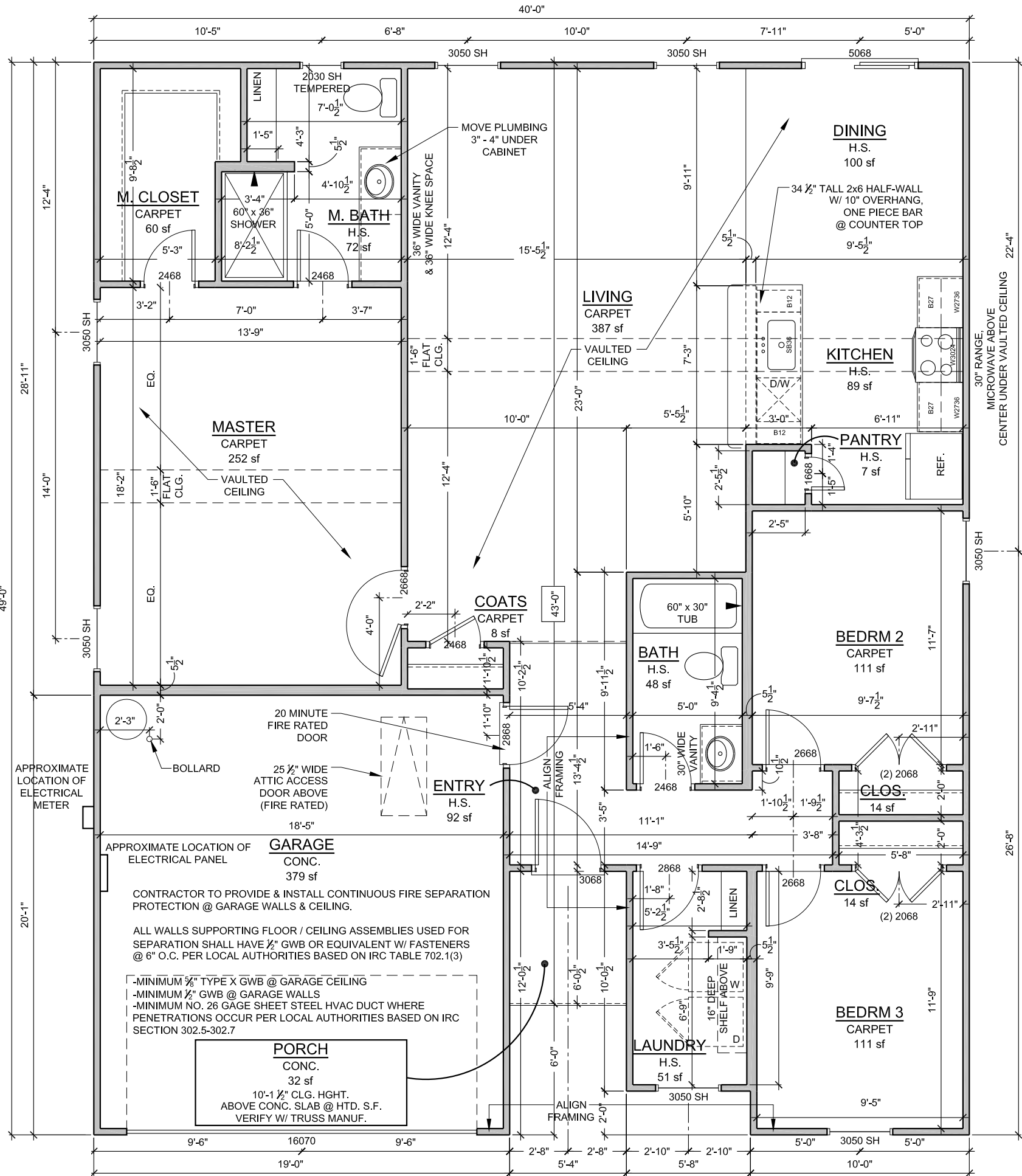

1 FIRST FLOOR PLAN
3/16" = 1'-0"



THE ALEXANDER

THESE DOCUMENTS ARE PROPERTY OF CDX ARCHITECTURE AND DESIGN AND SHALL NOT BE USED OR REPRODUCED WITHOUT WRITTEN CONSENT BY CDX ARCHITECTURE AND DESIGN. CDX ARCHITECTURE AND DESIGN SHALL NOT BE LIABLE FOR ANY UNAUTHORIZED USE OF THESE DOCUMENTS.

PERMIT SET FOR CONSTRUCTION

29 DECEMBER 2021

ELEVATIONS

A3.0

ELEVATION NOTES

- ALL REPRESENTATIONS OF GRADE LEVELS ARE FOR DRAWING PURPOSES ONLY, AND TO BE VERIFIED IN FIELD.
- ALL EXTERIOR ELEVATION DIMENSIONS ARE FRAMING DIMENSIONS, UNO. G.C. TO FILED VERIFY DIMENSIONS LOCATED AT SLOPED FRAMING AND / OR CONCRETE SLABS & PADS
- ALL TRUSS PROFILE DIMENSIONS TO BE VERIFIED BY TRUSS MANUFACTURER. TRUSS MANUFACTURER TO NOTIFY ARCHITECT IF TRUSS PROFILES / DIMENSIONS CHANGE.
- ALL BUILDINGS CONSTRUCTED WITH LESS THAN A 10' FIRE SEPARATION DISTANCE BETWEEN SHALL COMPLY WITH LOCAL AUTHORITIES BASED ON IRC (R302.1.1):
IN CONSTRUCTION USING VINYL OR ALUMINUM SOFFIT MATERIAL, THE FOLLOWING APPLICATION SHALL APPLY. SOFFIT ASSEMBLIES MUST BE SECURELY ATTACHED TO FRAMING MEMBERS AND APPLIED OVER FIRE-RETARDANT-TREATED WOOD, 23/32-INCH WOOD SHEATHING OR 5/8-INCH EXTERIOR GRADE OR MOISTURE RESISTANT GYPSUM BOARD. VENTING REQUIREMENTS SHALL BE PROVIDED IN BOTH SOFFIT AND UNDERLAYMENT. VENTS SHALL BE EITHER NOMINAL 2-INCH CONTINUOUS OR EQUIVALENT INTERMITTENT AND SHALL NOT EXCEED THE MINIMUM NET FREE AIR REQUIREMENTS ESTABLISHED IN SECTION R806.2 BY MORE THAN 50 PERCENT. TOWNHOME CONSTRUCTION SHALL MEET ADDITIONAL REQUIREMENTS OF SECTIONS R302.2.5 AND R302.2.6.

CEILING HEIGHT NOTES

8' - 1 1/2" CEILING HEIGHTS ON FIRST FLOOR

MEASURED FROM TOP OF SUBFLOOR / CONCRETE SLAB TO BOTTOM OF FLOOR JOISTS / ROOF TRUSSES

COLUMN NOTES

COLUMNS TO BE: AFCO OR COLUMN OF EQUAL BEARING CAPACITY. (6000 # MINIMUM)
 TOP CONNECTION: (2) #8 - 1/4" x 3" STAINLESS STEEL SCREWS PER SIDE INSERTED INTO BEAM.
 BOTTOM CONNECTION: (3) UBS - #18043 BRACKETS FASTENED WITH (2) 1/4" x 1 1/4" SCREWS INTO COLUMN & (2) 1/2" x 3 3/4" CONCRETE SCREWS THROUGH FASTENER INTO CONCRETE

ROOF NOTES

- CONTRACTORS TO FIELD VERIFY ALL DIMENSIONS & NOTIFY ARCHITECT OF ANY DISCREPANCIES, ERRORS OR OMISSIONS PRIOR TO EXECUTION OF WORK.
- ALL ROOF PENETRATIONS TO BE PLACED ON REAR SIDE OF MAIN RIDGE OR AS SPECIFIED BY ARCHITECT. PAINT TO MATCH SHINGLE COLOR.
- ATTIC INSULATION TO BE BATT. INSUL. PER CODE, PROVIDE BAFFLES @ PERIMETER TO ALLOW 2" FOR AIRFLOW FROM EAVE VENTS TO RIDGE VENTS.
- ROOF SHEATHING TO BE 1/2" T&G PLYWOOD W/ METAL CLIPS @ ENDS.
- ALL BATHROOM & DRYER VENT PENETRATIONS TO RUN TOWARD REAR OF HOUSE & VENT IN REAR OUTSIDE WALL OR ROOF BEHIND MAIN RIDGE.
- GUTTER & DOWNSPOUT INSTALLER TO PROVIDE ADEQUATE UNITS PER MANUFACTURER SPECIFICATIONS BASED ON ROOF COVERAGE. SUB-CONTRACTOR TO VERIFY NUMBER & LOCATION OF DOWNSPOUTS
- ALL SHINGLED ROOFS WITH A PITCH OF 4:12 OR LESS REQUIRE (2) LAYERS OF 30# FELT PAPER PER LOCAL AUTHORITIES BASED ON IRC 2018

INSULATION NOTES

INSULATION VALUES PER 2009 SC ECC CH. 3 & 4 ENERGY CONSERVATION CODE

COLUMBIA, SC
RICHLAND COUNTY - CLIMATE ZONE 3A

TABLE 402.1.1

CEILING: R-30
 FLOOR: R-19
 WALL: R-13

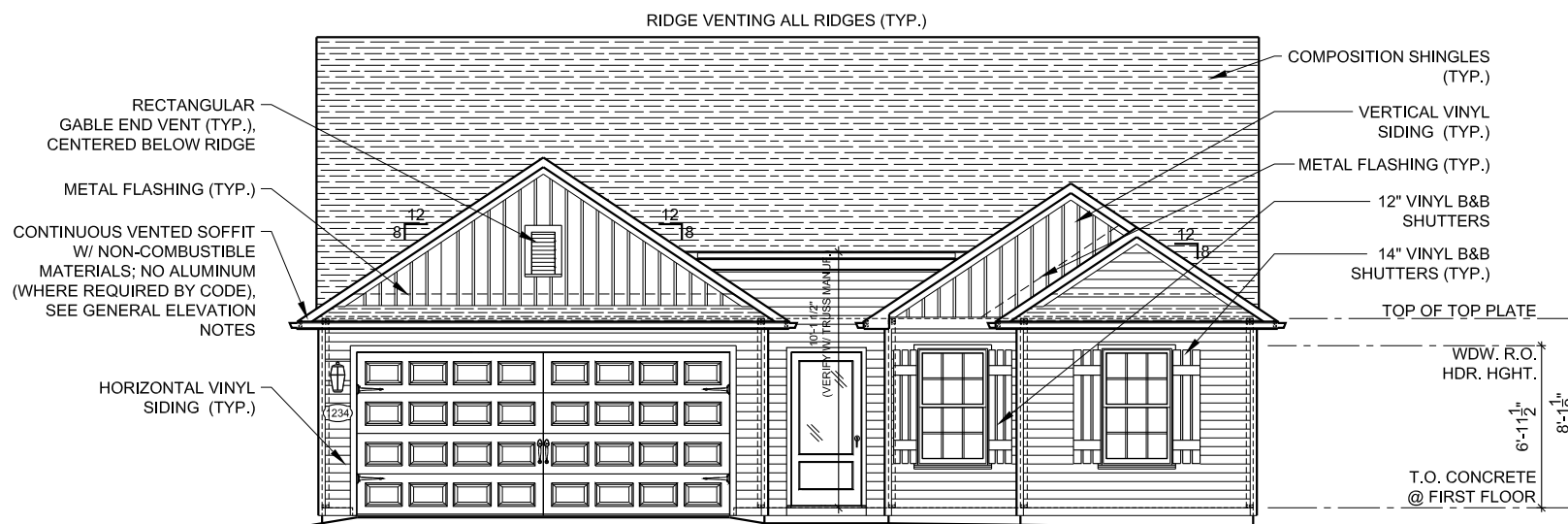

1 FRONT ELEVATION
1/8" = 1'-0"

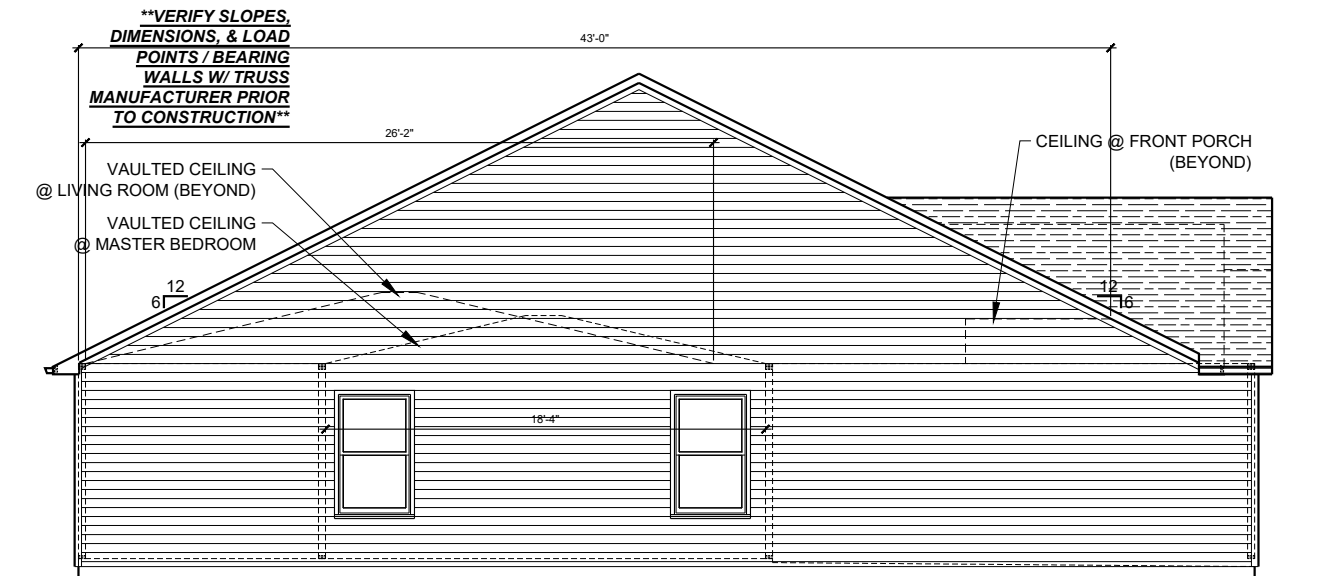

2 LEFT SIDE ELEVATION
1/8" = 1'-0"

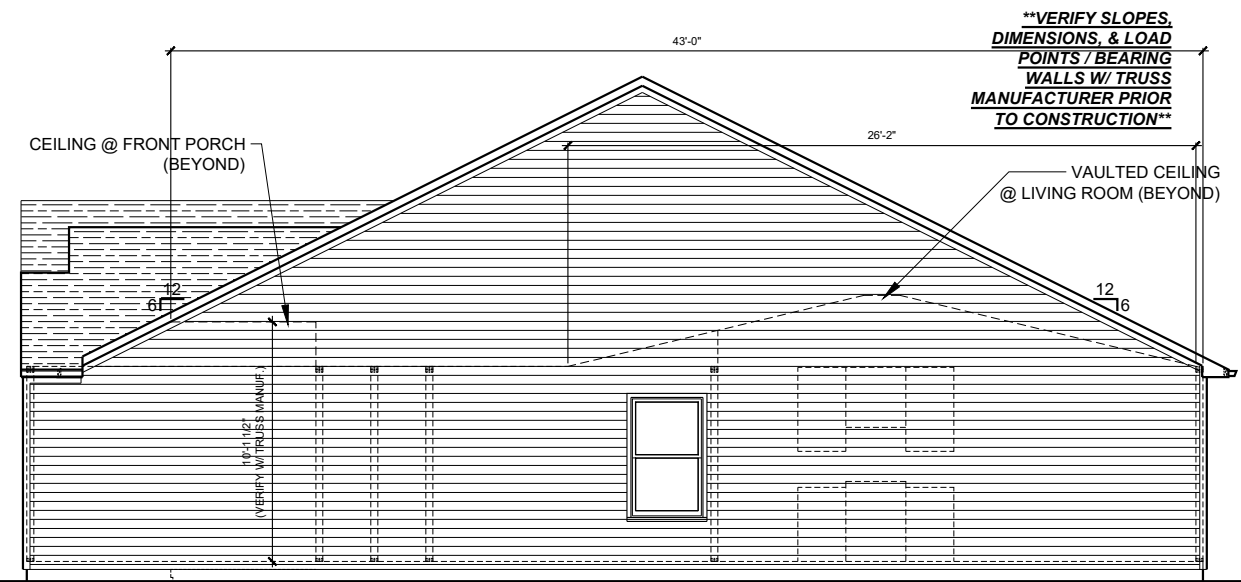

3 RIGHT SIDE ELEVATION
1/8" = 1'-0"



1 REAR ELEVATION
1/8" = 1'-0"

THE ALEXANDER

THESE DOCUMENTS ARE PROPERTY OF CDX ARCHITECTURE AND DESIGN AND SHALL NOT BE USED OR REPRODUCED WITHOUT WRITTEN CONSENT BY CDX ARCHITECTURE AND DESIGN. CDX ARCHITECTURE AND DESIGN SHALL NOT BE LIABLE FOR ANY UNAUTHORIZED USE OF THESE DOCUMENTS.

PERMIT SET FOR CONSTRUCTION

29 DECEMBER 2021

ELEVATIONS

A3.1

ELECTRICAL LEGEND

- | | | | |
|--|--|--|---|
| | 120 OUTLET, 18" A.F.F. TO CENTER OR 12" ABOVE COUNTERTOPS | | SMOKE/CARBON MONOXIDE DETECTOR |
| | G.F.I. 120 OUTLET, 18" A.F.F. TO CENTER OR 12" ABOVE COUNTERTOPS | | DOOR BELL |
| | WEATHER PROOF GFI 120 OUTLET | | DOOR BELL CHIME |
| | 240 OUTLET, COORDINATE EXACT LOCATION WITH EQUIPMENT SPECIFICATIONS | | DOOR BELL TRANSFORMER |
| | 1/2 SWITCHED 120 OUTLET, 18" A.F.F. TO CENTER OR 12" ABOVE COUNTERTOPS | | WALL SWITCH, 48" A.F.F. TO CENTER |
| | 120 QUADRAPLEX OUTLET, 18" A.F.F. TO CENTER | | DIMMER SWITCH, 48" A.F.F. TO CENTER |
| | USB OUTLET, 18" A.F.F. TO CENTER OR 12" ABOVE COUNTERTOPS | | 3 WAY SWITCH, 48" A.F.F. TO CENTER |
| | FLOOR 120 OUTLET (FLUSH) (TBD IN FIELD W/ OWNER) | | 4 WAY SWITCH, 48" A.F.F. TO CENTER |
| | JUNCTION BOX | | 3 WAY STACKED SWITCH |
| | CEILING LIGHT FIXTURE (LED) | | PHONE, 18" A.F.F. TO CENTER, 'W' INDICATES WALL MOUNTED @ 48" A.F.F. |
| | WALL LIGHT FIXTURE | | DATA, 18" A.F.F. TO CENTER, 'W' INDICATES WALL MOUNTED @ 48" A.F.F. |
| | 4" RECESSED LIGHT FIXTURE | | CABLE |
| | 4" RECESSED DAMP LOCATION LIGHT FIXTURE | | FLUORESCENT LIGHT FIXTURE |
| | 4" RECESSED EYEBALL FIXTURE | | ZENON UNDER CABINET LIGHT TO BE MTD. TO BOTTOM OF WALL CAB. NEAR FRONT EDGE |
| | FAN/LIGHT RECESSED FIXTURE | | PLUG MOLD TO BE MTD. TO BOTTOM OF WALL CAB. NEAR WALL |
| | FAN/LIGHT RECESSED DAMP LOCATION FIXTURE | | LED TAPE LIGHT |
| | CEILING FAN (*PROVIDE BLOCKING) | | DOOR OPENER |
| | FLOOD LIGHT | | ELECTRICAL PANEL |
| | THERMOSTAT | | ELECTRICAL METER |
| | EXHAUST FAN | | TANKLESS WATER HEATER |
| | | | HOSE BIBB |
| | | | GAS CONNECTION |
| | | | GAS SHUT-OFF |

ELECTRICAL NOTES

- LIGHT FIXTURES IN CLOSETS TO COMPLY WITH SECTION 410.8 OF THE LATEST VERSION OF THE NEC HANDBOOK
- SMOKE/CARBON MONOXIDE DETECTORS TO BE INSTALLED PER MANUFACTURER'S INSTRUCTIONS. QUANTITY AND LOCATION OF CARBON MONOXIDE DETECTORS TO BE DETERMINED BY LOCAL AUTHORITY.
- LIGHT SWITCHES & OUTLETS LOCATED AT COUNTERTOP SIDEWALLS ARE TO BE A MAXIMUM OF 18" FROM CENTERLINE OF SWITCH/OUTLET TO COUNTERTOP REAR WALL

ELECTRICAL PANEL / METER

- MAXIMUM DISTANCE BETWEEN ELECTRICAL PANEL & ELECTRICAL METER (NEC 230.70) TO BE DETERMINED BY LOCAL AUTHORITY.

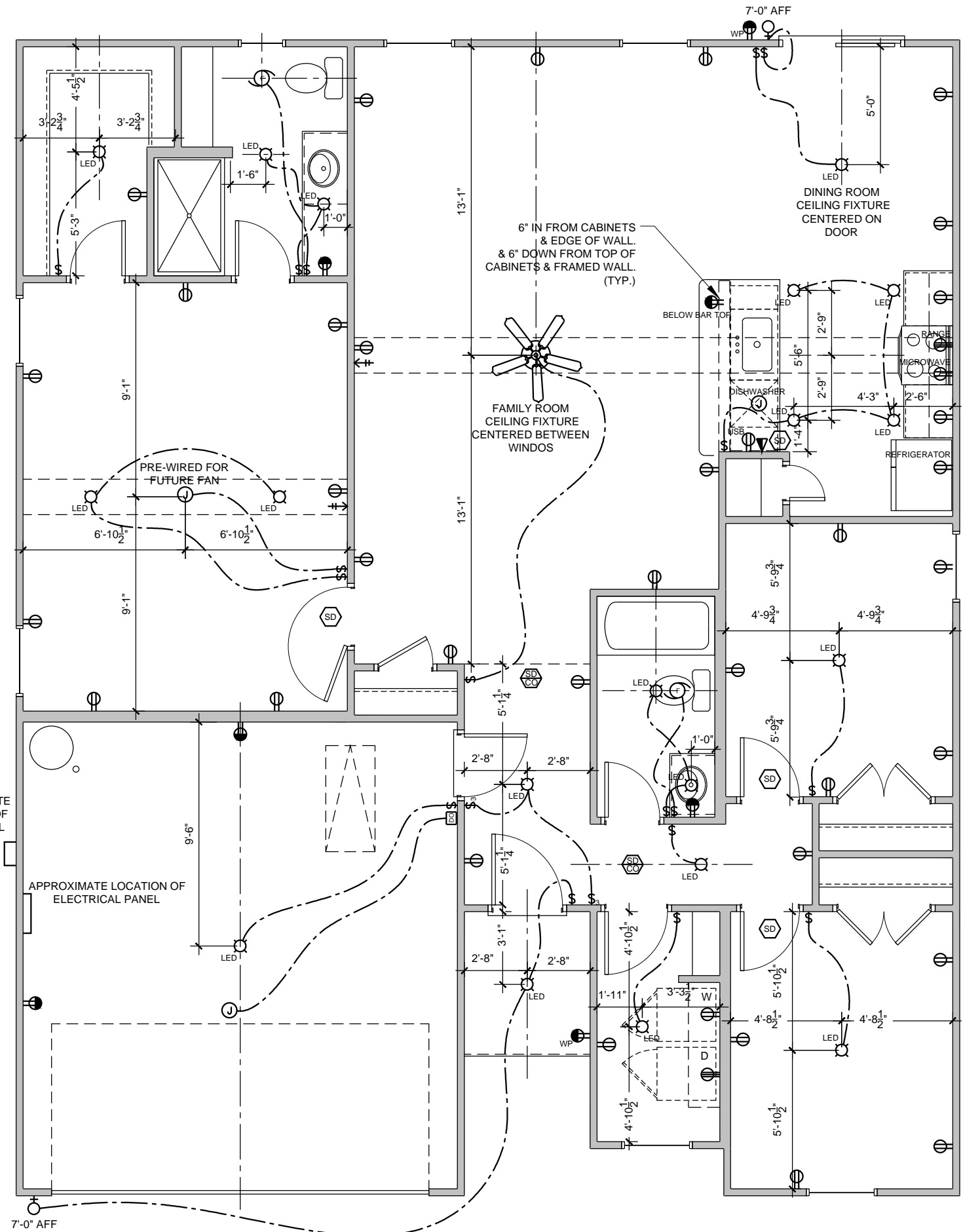

1 ELECTRICAL PLAN
3/16" = 1'-0"

THESE DOCUMENTS ARE PROPERTY OF CDX ARCHITECTURE AND DESIGN AND SHALL NOT BE USED OR REPRODUCED WITHOUT WRITTEN CONSENT BY CDX ARCHITECTURE AND DESIGN. CDX ARCHITECTURE AND DESIGN SHALL NOT BE LIABLE FOR ANY UNAUTHORIZED USE OF THESE DOCUMENTS.

PERMIT SET FOR CONSTRUCTION

29 DECEMBER 2021

ELECTRICAL PLAN

E1.0

DESIGN SPECIFICATIONS:

Construction Type: Commercial Residential

Applicable Building Codes:

- 2018 North Carolina Residential Building Code with All Local Amendments
- ASCE 7-10: Minimum Design Loads for Buildings and Other Structures

Design Loads:

- Roof Live Loads
 - Conventional 2x 20 PSF
 - Truss 20 PSF
 - Attic Truss 60 PSF
- Roof Dead Loads
 - Conventional 2x 10 PSF
 - Truss 20 PSF
- Snow 15 PSF
 - Importance Factor 1.0
- Floor Live Loads
 - Typ. Dwelling 40 PSF
 - Sleeping Areas 30 PSF
 - Decks 40 PSF
 - Passenger Garage 50 PSF
- Floor Dead Loads
 - Conventional 2x 10 PSF
 - I-Joist 15 PSF
 - Floor Truss 15 PSF
- Ultimate Design Wind Speed (3 sec. gust) 130 MPH
 - Exposure B
 - Importance Factor 1.0
 - Wind Base Shear
 - V_x =
 - V_y =
- Component and Cladding (in PSF)

MEAN ROOF HT.	UP TO 30'	30'-35'	35'-40'	40'-45'
ZONE 1	16.7-18.0	17.5-18.9	18.2-19.6	18.7-20.2
ZONE 2	16.7-21.0	17.5-22.1	18.2-22.9	18.7-23.5
ZONE 3	16.7-21.0	17.5-22.1	18.2-22.9	18.7-23.5
ZONE 4	18.2-19.0	19.2-20.0	19.9-20.7	20.4-21.3
ZONE 5	18.2-24.0	19.2-25.2	19.9-26.1	20.4-26.9

8. Seismic

- Site Class D
- Design Category C
- Importance Factor 1.0
- Seismic Use Group I
- Spectral Response Acceleration
 - S_{ms} = %g
 - S_{m1} = %g
- Seismic Base Shear
 - V_x =
 - V_y =
- Basic Structural System (check one)
 - Bearing Wall
 - Building Frame
 - Moment Frame
 - Dual w/ Special Moment Frame
 - Dual w/ Intermediate R/C or Special Steel
 - Inverted Pendulum
- ArchMech Components Anchored No
- Lateral Design Control: Seismic Wind
- Assumed Soil Bearing Capacity 2000psf



STRUCTURAL PLANS PREPARED FOR:

ALEXANDER

PROJECT ADDRESS:

TBD

OWNER:

LGI Homes
7201 Creedmoor Road, Suite 147
Raleigh, NC 27613

ARCHITECT/DESIGNER:

COX Architecture & Design, PLLC
1310 South Tryon Street, Suite 111
Charlotte, NC 28203

These drawings are to be coordinated with the architectural, mechanical, plumbing, electrical, and civil drawings. This coordination is not the responsibility of the structural engineering of record (SER). Should any discrepancies become apparent, the contractor shall notify SUMMIT Engineering, Laboratory & Testing, INC. before construction begins.

PLAN ABBREVIATIONS:

AB	ANCHOR BOLT	PT	PRESSURE TREATED
AFF	ABOVE FINISHED FLOOR	RS	ROOF SUPPORT
CJ	CEILING JOIST	SC	STUD COLUMN
CLR	CLEAR	SJ	SINGLE JOIST
DJ	DOUBLE JOIST	SPF	SPRUCE PINE FIR
DSP	DOUBLE STUD POCKET	SST	SIMPSON STRONG-TIE
EE	EACH END	SYP	SOUTHERN YELLOW PINE
EW	EACH WAY	TJ	TRIPLE JOIST
NTS	NOT TO SCALE	TSP	TRIPLE STUD POCKET
OC	ON CENTER	TYP	TYPICAL
PSF	POUNDS PER SQUARE FOOT	UNO	UNLESS NOTED OTHERWISE
PSI	POUNDS PER SQUARE INCH	WUF	WELDED WIRE FABRIC

Roof truss and floor joist layouts, and their corresponding loading details, were not provided to SUMMIT Engineering, Laboratory & Testing, INC. (SUMMIT) prior to the initial design. Therefore, truss and joist directions were assumed based on the information provided by LGI HOMES. Subsequent plan revisions based on roof truss and floor joist layouts shall be noted in the revision list, indicating the date the layouts were provided. Should any discrepancies become apparent, the contractor shall notify SUMMIT immediately.

SHEET LIST:

Sheet No.	Description
CS1	Cover Sheet, Specifications, Revisions
CS2	Specifications Continued
SI.0m	Monolithic Slab Foundation
SI.0s	Stem Wall Foundation
SI.0c	Crawl Space Foundation
SI.0.4b	4-Sides Brick Crawl Space Foundation
SI.0b	Basement Foundation
S2.0	Basement Framing Plan
S3.0	First Floor Framing Plan
S4.0	Second Floor Framing Plan
S5.0	Roof Framing Plan
S6.0	Basement Bracing Plan
S7.0	First Floor Bracing Plan
S8.0	Second Floor Bracing Plan

Revision No.	Date	Project No.	Description
0	1/30/19	26545	Original Engineering
1	1/7/21	26545R1	Add stick frame roof option
2	2/2/21	26545R2	Revised to have thermo ply bracing
3	10/18/21	26545R3	Revised per new architecturals
4	12/29/21	26545R4	Updated Seal

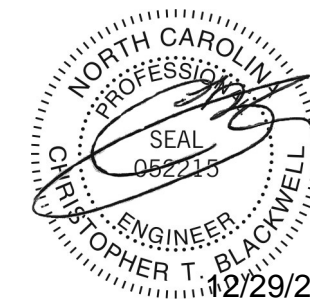

STRUCTURAL MEMBERS ONLY

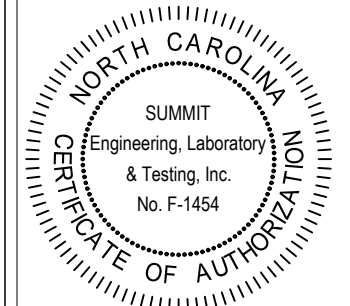

ALEXANDER (LH)
Coversheet
LGI Homes
7201 Creedmoor Road, Suite 147
Raleigh, NC 27613

CURRENT DRAWING

DATE: 12/29/2021

SCALE: 1/8"=1'-0"

PROJECT #: 1203-08R: 26545

DRAWN BY: BAF

CHECKED BY: CTB

ORIGINAL DRAWING

DATE PROJECT #
1/29/2020 26545

REFER TO COVER SHEET FOR A COMPLETE LIST OF REVISIONS

SHEET

CS1

GENERAL STRUCTURAL NOTES:

- The design professional whose seal appears on these drawings is the structural engineer of record (SER) for this project. The SER bears the responsibility of the primary structural elements and the performance of this structure. No other party may revise, alter, or delete any structural aspects of these construction documents without written permission of SUMMIT Engineering, Laboratory & Testing, INC. (SUMMIT) or the SER. For the purposes of these construction documents the SER and SUMMIT shall be considered the same entity.
- The structure is only stable in its completed form. The contractor shall provide all required temporary bracing during construction to stabilize the structure.
- The SER is not responsible for construction sequences, methods, or techniques in connection with the construction of this structure. The SER will not be held responsible for the contractor's failure to conform to the contract documents, should any non-conformities occur.
- Any structural elements or details not fully developed on the construction drawings shall be completed under the direction of a licensed professional engineer. These shop drawings shall be submitted to SUMMIT for review before any construction begins. The shop drawings will be reviewed for overall compliance as it relates to the structural design of this project. Verification of the shop drawings for dimensions, or for actual field conditions, is not the responsibility of the SER or SUMMIT.
- Verification of assumed field conditions is not the responsibility of the SER. The contractor shall verify the field conditions for accuracy and report any discrepancies to SUMMIT before construction begins.
- The SER is not responsible for any secondary structural elements or non-structural elements, except for the elements specifically noted on the structural drawings.
- This structure and all construction shall conform to all applicable sections of the international residential code.
- This structure and all construction shall conform to all applicable sections of local building codes.
- All structural assemblies are to meet or exceed to requirements of the current local building code.

FOUNDATIONS:

- The structural engineer has not performed a subsurface investigation. Verification of this assumed value is the responsibility of the owner or the contractor. Should any adverse soil condition be encountered the SER must be contacted before proceeding.
- The bottom of all footings shall extend below the frost line for the region in which the structure is to be constructed. However, the bottom of all footings shall be a minimum of 12" below grade.
- Any fill shall be placed under the direction or recommendation of a licensed professional engineer.
- The resulting soil shall be compacted to a minimum of 95% maximum dry density.
- Excavations of footings shall be lined temporarily with a 6 mil polyethylene membrane if placement of concrete does not occur within 24 hours of excavation.
- No concrete shall be placed against any subgrade containing water, ice, frost, or loose material.

STRUCTURAL STEEL:

- Structural steel shall be fabricated and erected in accordance with the American Institute of Steel Construction "Code of Standard Practice for Steel Buildings and Bridges" and the manual of Steel Construction "Load Resistance Factor Design" latest editions.
- Structural steel shall receive one coat of shop applied rust-inhibitive paint.
- All steel shall have a minimum yield stress (F_y) of 36 ksi unless otherwise noted.
- Welding shall conform to the latest edition of the American Welding Society's Structural Welding Code AWS D11. Electrodes for shop and field welding shall be class E70XX. All welding shall be performed by a certified welder per the above standards.

CONCRETE:

- Concrete shall have a normal weight aggregate and a minimum compressive strength (f'_c) at 28 days of 3000 psi, unless otherwise noted on the plan.
- Concrete shall be proportioned, mixed, and placed in accordance with the latest editions of ACI 318: "Building Code Requirements for Reinforced Concrete" and ACI 301: "Specifications for Structural Concrete for Buildings".
- Air entrained concrete must be used for all structural elements exposed to freeze/thaw cycles and deicing chemicals. Air entrainment amounts (in percent) shall be within -1% to +2% of target values as follows:
 - Footings: 5%
 - Exterior Slabs: 5%
- No admixtures shall be added to any structural concrete without written permission of the SER.
- Concrete slabs-on-grade shall be constructed in accordance with ACI 302.1R-96: "Guide for Concrete Slab and Slab Construction".
- The concrete slab-on-grade has been designed using a subgrade modulus of $k=250$ pci and a design loading of 200 psf. The SER is not responsible for differential settlement, slab cracking or other future defects resulting from unreported conditions not in accordance with the above assumptions.
- Control or saw cut joints shall be spaced in interior slabs-on-grade at a maximum of 15'-0" O.C. and in exterior slabs-on-grade at a maximum of 10'-0" unless otherwise noted.
- Control or saw cut joints shall be produced using conventional process within 4 to 12 hours after the slab has been finished.
- Reinforcing steel may not extend through a control joint. Reinforcing steel may extend through a saw cut joint.
- All welded wire fabric (WWF) for concrete slabs-on-grade shall be placed at mid-depth of slab. The WWF shall be securely supported during the concrete pour.

CONCRETE REINFORCEMENT:

- Fibrous concrete reinforcement, or fiber mesh, specified in concrete slabs-on-grade may be used for control of cracking due to shrinkage and thermal expansion/contraction, lowered water migration, an increase in impact capacity, increased abrasion resistance, and residual strength.
- Fiber mesh reinforcing to be 100% virgin polypropylene fibers containing no reprocessed olefin materials and specifically manufactured for use as concrete secondary reinforcement.
- Application of fiber mesh per cubic yard of concrete shall equal a minimum of 0.1% by volume (15 pounds per cubic yard)
- Fiber mesh shall comply with ASTM C1116, any local building code requirements, and shall meet or exceed the current industry standard.
- Steel reinforcing bars shall be new billet steel conforming to ASTM A615, grade 60.
- Detailing, fabrication, and placement of reinforcing steel shall be in accordance with the latest edition of ACI 315: "Manual of Standard Practice for Detailing Concrete Structures"
- Horizontal footing and wall reinforcement shall be continuous and shall have 90° bends, or corner bars with the same size/spacing as the horizontal reinforcement with a class B tension splice.
- Lap reinforcement as required, a minimum of 40 bar diameters for tension or compression unless otherwise noted. Splices in masonry shall be a minimum of 48 bar diameters.
- Where reinforcing dowels are required, they shall be equivalent in size and spacing to the vertical reinforcement. The dowel shall extend 48 bar diameters vertically and 20 bar diameters into the footing.
- Where reinforcing steel is required vertically, dowels shall be provided unless otherwise noted.

WOOD FRAMING:

- Solid sawn wood framing members shall conform to the specifications listed in the latest edition of the "National Design Specification for Wood Construction" (NDS). Unless otherwise noted, all wood framing members are designed to be Southern-Yellow-Pine (SYP) #2.
- LVL or PSL engineered wood shall have the following minimum design values:
 - E = 1,900,000 psi
 - Fb = 2600 psi
 - Fv = 285 psi
 - Fc = 100 psi
- Wood in contact with concrete, masonry, or earth shall be pressure treated in accordance with AWWPA standard C-15. All other moisture exposed wood shall be treated in accordance with AWWPA standard C-2
- Nails shall be common wire nails unless otherwise noted.
- Lag screws shall conform to ANSI/ASME standard B18.2.1-1981. Lead holes for lag screws shall be in accordance with NDS specifications.
- All beams shall have full bearing on supporting framing members unless otherwise noted.
- Exterior and load bearing stud walls are to be 2x4 SYP #2 @ 16" O.C. unless otherwise noted. Studs shall be continuous from the sole plate to the double top plate. Studs shall only be discontinuous at headers for window/door openings. A minimum of one king stud shall be placed at each end of the header. King studs shall be continuous.
- Individual studs forming a column shall be attached with one 10d nail @ 6" O.C. staggered. The stud column shall be continuous to the foundation or beam. The column shall be properly blocked at all floor levels to ensure proper load transfer.
- Multi-ply beams shall have each ply attached with (3) 10d nails @ 24" O.C.
- Four and five ply beams shall be bolted together with (2) rows of 1/2" diameter through bolts staggered @ 16" O.C. unless noted otherwise.

WOOD TRUSSES:

- The wood truss manufacturer/fabricator is responsible for the design of the wood trusses. Submit sealed shop drawings and supporting calculations to the SER for review prior to fabrication. The SER shall have a minimum of five (5) days for review. The review by the SER shall review for overall compliance with the design documents. The SER shall assume no responsibility for the correctness for the structural design for the wood trusses.
- The wood trusses shall be designed for all required loadings as specified in the local building code, the ASCE Standard "Minimum Design Loads for Buildings and Other Structures." (ASCE 7-10), and the loading requirements shown on these specifications. The truss drawings shall be coordinated with all other construction documents and provisions provided for loads shown on these drawings including but not limited to HVAC equipment, piping, and architectural fixtures attached to the trusses.
- The trusses shall be designed, fabricated, and erected in accordance with the latest edition of the "National Design Specification for Wood Construction." (NDS) and "Design Specification for Metal Plate Connected Wood Trusses."
- The truss manufacturer shall provide adequate bracing information in accordance with "Commentary and Recommendations for Handling, Installing, and Bracing Metal Plate Connected Wood Trusses" (HIB-91). This bracing, both temporary and permanent, shall be shown on the shop drawings. Also, the shop drawings shall show the required attachments for the trusses.
- Any chords or truss webs shown on these drawings have been shown as a reference only. The final design of the trusses shall be per the manufacturer.

EXTERIOR WOOD FRAMED DECKS:

- Decks are to be framed in accordance with local building codes and as referenced on the structural plans, either through code references or construction details.

WOOD STRUCTURAL PANELS:

- Fabrication and placement of structural wood sheathing shall be in accordance with the APA Design/Construction Guide "Residential and Commercial," and all other applicable APA standards.
- All structurally required wood sheathing shall bear the mark of the APA.
- Wood wall sheathing shall comply with the requirements of local building codes for the appropriate state as indicated on these drawings. Refer to wall bracing notes in plan set for more information. Sheathing shall be applied with the long direction perpendicular to framing, unless noted otherwise.
- Roof sheathing shall be APA rated sheathing exposure 1 or 2. Roof sheathing shall be continuous over two supports and attached to its supporting roof framing with (1)-8d CC nail at 6"o/c at panel edges and at 12"o/c in panel field unless otherwise noted on the plans. Sheathing shall be applied with the long direction perpendicular to framing. Sheathing shall have a span rating consistent with the framing spacing. Use suitable edge support by use of plywood clips or lumber blocking unless otherwise noted. Panel end joints shall occur over framing. Apply building paper over the sheathing as required by the state Building Code.
- Wood floor sheathing shall be APA rated sheathing exposure 1 or 2. Attach sheathing to its supporting framing with (1)-8d CC ringshank nail at 6"o/c at panel edges and at 12"o/c in panel field unless otherwise noted on the plans. Sheathing shall be applied perpendicular to framing. Sheathing shall have a span rating consistent with the framing spacing. Use suitable edge support by use of T&G plywood or lumber blocking unless otherwise noted. Panel end joints shall occur over framing. Apply building paper over the sheathing as required by the state Building Code.
- Sheathing shall have a 1/8" gap at panel ends and edges as recommended in accordance with the APA.

STRUCTURAL FIBERBOARD PANELS:

- Fabrication and placement of structural fiberboard sheathing shall be in accordance with the applicable AFA standards.
- All structurally required fiberboard sheathing shall bear the mark of the AFA.
- Fiberboard wall sheathing shall comply with the requirements of local building codes for the appropriate state as indicated on these drawings. Refer to wall bracing notes in plan set for more information.
- Sheathing shall have a 1/8" gap at panel ends and edges as recommended in accordance with the AFA.



STRUCTURAL MEMBERS ONLY

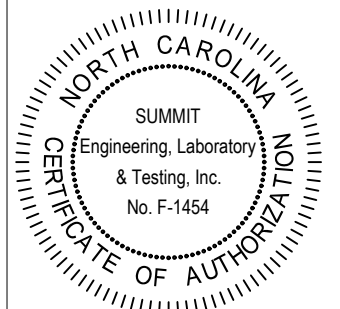

ALEXANDER (LH)
 Coversheet
 LGI Homes
 7201 Creedmoor Road, Suite 147
 Raleigh, NC 27613

CURRENT DRAWING
 DATE: 12/29/2021
 SCALE: 1/8"=1'-0"
 PROJECT #: 1203-08R: 26545
 DRAWN BY: BAF
 CHECKED BY: CTB

ORIGINAL DRAWING
 DATE PROJECT #
 1/29/2020 26545

REFER TO COVER SHEET FOR A COMPLETE LIST OF REVISIONS

SHEET

CS2

FOUNDATION NOTES:

- FOUNDATIONS TO BE CONSTRUCTED IN ACCORDANCE w/ CHAPTER 4 OF THE 2018 NORTH CAROLINA RESIDENTIAL BUILDING CODE w/ ALL LOCAL AMENDMENTS.
- STRUCTURAL CONCRETE TO BE F_c = 3000 PSI, PREPARED AND PLACED IN ACCORDANCE WITH ACI STANDARD 318.
- FOOTINGS TO BE PLACED ON UNDISTURBED EARTH BEARING A MINIMUM OF 12" BELOW ADJACENT FINISHED GRADE, OR AS OTHERWISE DIRECTED BY THE CODE ENFORCEMENT OFFICIAL.
- FOOTING SIZES BASED ON A PRESUMPTIVE SOIL BEARING CAPACITY OF 2000 PSF. CONTRACTOR IS SOLELY RESPONSIBLE FOR VERIFYING THE SUITABILITY OF THE SITE SOIL CONDITIONS AT THE TIME OF CONSTRUCTION.
- FOOTINGS AND PIERS SHALL BE CENTERED UNDER THEIR RESPECTIVE ELEMENTS. PROVIDE 2" MINIMUM FOOTING PROJECTION FROM THE FACE OF MASONRY.
- MAXIMUM DEPTH OF UNBALANCED FILL AGAINST MASONRY WALLS TO BE AS SPECIFIED IN SECTION R404.1 OF THE 2018 NORTH CAROLINA RESIDENTIAL BUILDING CODE.
- FILASTERS TO BE BONDED TO PERIMETER FOUNDATION WALL.
- PROVIDE FOUNDATION WATERPROOFING, AND DRAIN WITH POSITIVE SLOPE TO OUTLET AS REQUIRED BY SITE CONDITIONS.
- PROVIDED PERIMETER INSULATION FOR ALL FOUNDATIONS PER 2018 NORTH CAROLINA RESIDENTIAL BUILDING CODE.
- CORBEL FOUNDATION WALL AS REQUIRED TO ACCOMMODATE BRICK VENEERS.
- CRACK SPACE TO BE GRADED LEVEL, AND CLEARED OF ALL DEBRIS.
- FOUNDATION ANCHORAGE SHALL BE CONSTRUCTED PER THE 2018 NORTH CAROLINA RESIDENTIAL CODE SECTION R403.6. MINIMUM 1/2" DIA BOLTS SPACED AT 6'-0" ON CENTER WITH A 1" MINIMUM EMBEDMENT INTO MASONRY OR CONCRETE. MINIMUM (2) ANCHOR BOLTS PER PLATE SECTION AND (1) LOCATED NOT MORE THAN 12" FROM THE CORNER. ANCHOR BOLTS SHALL BE LOCATED IN THE CENTER THIRD OF THE PLATE.
- ABBREVIATIONS:

- | | |
|-------------------|--------------------|
| DJ = DOUBLE JOIST | SJ = SINGLE JOIST |
| GT = GIRDER TRUSS | FT = FLOOR TRUSS |
| SC = STUD COLUMN | DR = DOUBLE RAFTER |
| EE = EACH END | TR = TRIPLE RAFTER |
| TJ = TRIPLE JOIST | OC = ON CENTER |
| CL = CENTER LINE | PL = POINT LOAD |

- ALL PIERS TO BE 16"x16" MASONRY AND ALL FILASTERS TO BE 8"x16" MASONRY, TYPICAL (UNO).
- WALL FOOTINGS TO BE CONTINUOUS CONCRETE, SIZES PER STRUCTURAL PLAN.
- A FOUNDATION EXCAVATION OBSERVATION SHOULD BE CONDUCTED BY A PROFESSIONAL GEOTECHNICAL ENGINEER OR HIS QUALIFIED REPRESENTATIVE. IF ISOLATED AREAS OF YIELDING MATERIALS AND/OR POTENTIALLY EXPANSIVE SOILS ARE OBSERVED IN THE FOOTING EXCAVATIONS AT THE TIME OF CONSTRUCTION, SUMMIT ENGINEERING, LABORATORY & TESTING, INC. MUST BE PROVIDED THE OPPORTUNITY TO REVIEW THE FOOTING DESIGN PRIOR TO CONCRETE PLACEMENT.
- ALL FOOTINGS & SLABS ARE TO BEAR ON UNDISTURBED SOIL OR 95% COMPACTED FILL, VERIFIED BY ENGINEER OR CODE OFFICIAL.

REFER TO BRACED WALL PLAN FOR PANEL LOCATIONS AND ANY REQUIRED HOLD-DOWNS. ADDITIONAL INFORMATION PER SECTION R602.10.8 AND FIGURE R602.10.1 OF THE 2018 IRC.

NOTE: ALL EXTERIOR FOUNDATION DIMENSIONS ARE TO FRAMING AND NOT BRICK VENEER, UNO.

NOTE: A 4" CRUSHED STONE BASE COURSE IS NOT REQUIRED WHEN SLAB IS INSTALLED ON WELL-DRAINED OR SAND-GRAVEL MIXTURE SOILS CLASSIFIED AS GROUP 1 PER TABLE R409.1.

NOTE: FOUNDATION ANCHORAGE HAS BEEN DESIGNED TO RESIST THE CONTINUOUS WIND UPLIFT LOAD PATH IN ACCORDANCE WITH METHOD 3 OF SECTION R602.3.5 OF THE 2018 NCR. C.

THESE PLANS ARE DESIGNED IN ACCORDANCE WITH ARCHITECTURAL PLANS PROVIDED BY LGI HOMES COMPLETED/REVISED ON 12/29/2021. IT IS THE RESPONSIBILITY OF THE CLIENT TO NOTIFY SUMMIT ENGINEERING, LABORATORY & TESTING, INC. IF ANY CHANGES ARE MADE TO THE ARCHITECTURAL PLANS PRIOR TO CONSTRUCTION. SUMMIT CANNOT GUARANTEE THE ADEQUACY OF THESE STRUCTURAL PLANS WHEN USED WITH ARCHITECTURAL PLANS DATED DIFFERENTLY THAN THE DATE LISTED ABOVE.

ROOF TRUSS AND FLOOR JOIST LAYOUTS, AND THEIR CORRESPONDING LOADING DETAILS, WERE NOT PROVIDED TO SUMMIT ENGINEERING, LABORATORY & TESTING, INC. (SUMMIT) PRIOR TO THE INITIAL DESIGN. THEREFORE, TRUSS AND JOIST DIRECTIONS WERE ASSUMED BASED ON THE INFORMATION PROVIDED BY LGI HOMES. SUBSEQUENT PLAN REVISIONS BASED ON ROOF TRUSS AND FLOOR JOIST LAYOUTS SHALL BE NOTED IN THE REVISION LIST, INDICATING THE DATE THE LAYOUTS WERE PROVIDED. SHOULD ANY DISCREPANCIES BECOME APPARENT, THE CONTRACTOR SHALL NOTIFY SUMMIT IMMEDIATELY.

STRUCTURAL MEMBERS ONLY

ENGINEERING SEAL APPLIES ONLY TO STRUCTURAL COMPONENTS ON THIS DOCUMENT. SEAL DOES NOT INCLUDE CONSTRUCTION MEANS, METHODS, TECHNIQUES, SEQUENCES, PROCEDURES OR SAFETY PRECAUTIONS. ANY DEVIATIONS OR DISCREPANCIES ON PLANS ARE TO BE BROUGHT TO THE IMMEDIATE ATTENTION OF SUMMIT ENGINEERING, LABORATORY & TESTING, INC. FAILURE TO DO SO WILL VOID SUMMIT LIABILITY.

STRUCTURAL ANALYSIS BASED ON 2018 NCR. C.

MONOLITHIC SLAB FOUNDATION

SCALE: 1/8"=1'

FOUNDATION SCHEDULE		
TAG	DESCRIPTION	REBAR REQ'D
1	16"SQ x 10"D	NONE
2	24"SQ x 10"D	NONE
3	30"SQ x 10"D	NONE
4	36"SQ x 12"D	NONE
5	42"SQ x 12"D	(4) #4 EW.
6	48"SQ x 12"D	(6) #4 EW.
◇	4" THICK POURED CONCRETE SLAB w/ FIBER MESH ON 6 MIL POLY ON COMPACTED SOIL	
◇	4" THICK POURED CONCRETE SLAB ON COMPACTED SOIL	

ABBREVIATIONS: W = WIDTH, D = DEPTH, SQ = SQUARE, B.D. = BOTH DIRECTIONS, CONT. = CONTINUOUS, MONO = MONOLITHIC SLAB FOOTING

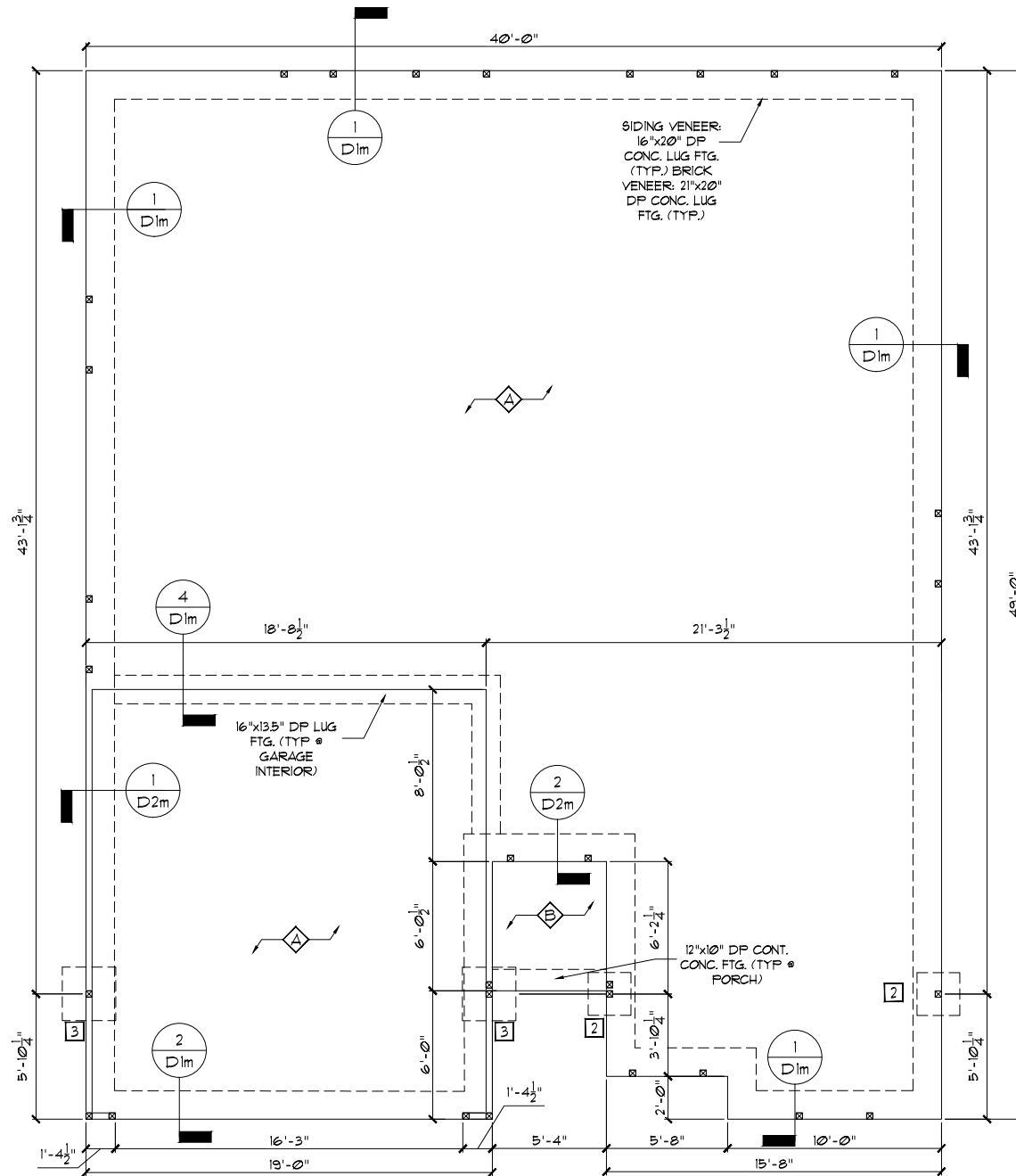

ALL ELEVATIONS- ROOF TRUSS ROOFS

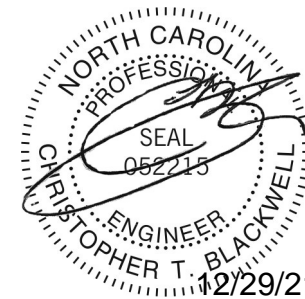

STRUCTURAL MEMBERS ONLY

SUMMIT
ENGINEERING LABORATORY TESTING
3070 HAMMOND BUSINESS PLACE, SUITE 171
RALEIGH, NC 27603
OFFICE: 919.380.9991
FAX: 919.380.9993
WWW.SUMMIT-COMPANIES.COM

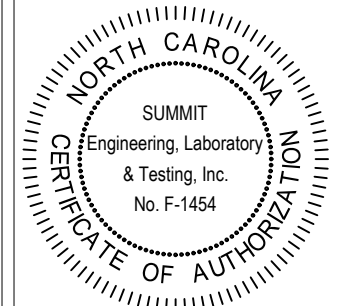

ALEXANDER (LH)
Monolithic Slab Fnd.
LGI Homes
7201 Creedmoor Road, Suite 147
Raleigh, NC 27613

CURRENT DRAWING	
DATE: 12/29/2021	PROJECT #: 1203-08R: 26545
SCALE: 1/8"=1'-0"	DRAWN BY: BAF
CHECKED BY: CTB	
ORIGINAL DRAWING	
DATE: 1/29/2020	PROJECT #: 26545

REFER TO COVER SHEET FOR A COMPLETE LIST OF REVISIONS

SHEET

S1.0m

GENERAL STRUCTURAL NOTES:

- CONSTRUCTION SHALL CONFORM TO 2018 NORTH CAROLINA RESIDENTIAL BUILDING CODE WITH ALL LOCAL AMENDMENTS.
- CONTRACTOR SHALL VERIFY ALL DIMENSIONS. CONTRACTOR SHALL COMPLY WITH THE CONTENTS OF THE DRAWINGS FOR THIS SPECIFIC PROJECT. ENGINEER IS NOT RESPONSIBLE FOR ANY DEVIATIONS FROM THIS PLAN.
- CONTRACTOR IS RESPONSIBLE FOR PROVIDING TEMPORARY BRACING REQUIRED TO RESIST ALL FORCES ENCOUNTERED DURING ERECTION.
- PROPERTIES USED IN THE DESIGN ARE AS FOLLOWS:
MICROLAM (LVL): $F_y = 26000$ PSI, $F_x = 225$ PSI, $E = 1.9 \times 10^6$ PSI
TIMBERSTRAND (LSL): $F_y = 2325$ PSI, $F_x = 310$ PSI, $E = 1.55 \times 10^6$ PSI
PARALLAM (PSL): $F_y = 29000$ PSI, $F_x = 290$ PSI, $E = 1.25 \times 10^6$ PSI
- ALL WOOD MEMBERS SHALL BE #2 SYP UNLESS NOTED ON PLAN. ALL STUD COLUMNS AND JOISTS SHALL BE #2 SYP (UNO).
- ALL BEAMS SHALL BE SUPPORTED WITH A (2) 2x4 #2 SYP STUD COLUMN AT EACH END UNLESS NOTED OTHERWISE.
- ALL REINFORCING STEEL SHALL BE GRADE 60 BARS CONFORMING TO ASTM A635 AND SHALL HAVE A MINIMUM COVER OF 3".
- FOUNDATION ANCHORAGE SHALL BE CONSTRUCTED PER THE 2018 NORTH CAROLINA RESIDENTIAL CODE SECTION R403.6. MINIMUM 10" DIA. BOLTS SPACED AT 6'-0" ON CENTER WITH A 1" MINIMUM EMBEDMENT INTO MASONRY OR CONCRETE. MINIMUM (2) ANCHOR BOLTS PER PLATE SECTION AND (1) LOCATED NOT MORE THAN 12" FROM THE CORNER. ANCHOR BOLTS SHALL BE LOCATED IN THE CENTER THIRD OF THE PLATE.
- CONTRACTOR TO PROVIDE LOOKOUTS WHEN CEILING JOISTS SPAN PERPENDICULAR TO RAFTERS.
- FLITCH BEAMS, 4-PLY LVL'S AND 3-PLY SIDE LOADED LVL'S SHALL BE BOLTED TOGETHER WITH 1/2" DIA. THRU BOLTS SPACED AT 24" O.C. (MAX) STAGGERED OR EQUIVALENT CONNECTIONS PER DETAIL 1071. MIN. EDGE DISTANCE SHALL BE 2" AND BOLTS SHALL BE LOCATED MINIMUM 6" FROM EACH END OF THE BEAM.
- ALL NON-LOAD BEARING HEADERS SHALL BE (1) FLAT 2x4 SYP #2, DROPPED. FOR NON-LOAD BEARING HEADERS EXCEEDING 8'-0" IN WIDTH AND/OR WITH MORE THAN 2'-0" OF CRIPPLE WALL ABOVE, SHALL BE (2) FLAT 2x4 SYP #2, DROPPED. (UNLESS NOTED OTHERWISE)
- ABBREVIATIONS:

- | | |
|-------------------|--------------------|
| DJ = DOUBLE JOIST | SJ = SINGLE JOIST |
| GT = GIRDER TRUSS | FT = FLOOR TRUSS |
| SC = STUD COLUMN | DR = DOUBLE RAFTER |
| EE = EACH END | TR = TRIPLE RAFTER |
| TJ = TRIPLE JOIST | OC = ON CENTER |
| CL = CENTER LINE | PL = POINT LOAD |

WALL STUD SCHEDULE (10 FT HEIGHT)				
STUD SIZE	STUD SPACING (O.C.)			
	ROOF ONLY	ROOF & 1 FLOOR	ROOF & 2 FLOORS	NON-LOAD BEARING
2x4	24"	16"	12"	24"
2x6	24"	24"	16"	24"

- NOTES:**
- BRACED WALLS STUDS SHALL BE A MAX. OF 16" O.C.
 - STUDS SUPPORTS OPTIONAL WALK-UP ATTIC SHALL BE SPACED A MAX. OF 16" O.C.
 - TWO STORY WALLS SHALL BE FRAMED W/ 2x4 STUDS @ 12" O.C. OR 2x6 STUDS @ 16" O.C. BALLOON FRAMED W/ HORIZONTAL BLOCKING @ 6'-0" O.C. VERTICALLY.

LINTEL SCHEDULE		
TAG	SIZE	OPENING SIZE
①	L3x3x1/4"	LESS THAN 6'-0"
②	L5x3x1/4"	6'-0" TO 10'-0"
③	L5x3-1/2x5/16"	GREATER THAN 10'-0"
④	L5x3-1/2x5/16"	ALL ARCHED OPENINGS

- NOTES:**
- SECURE LINTEL TO HEADER W/ (2) 1/2" DIAMETER LAG SCREWS STAGGERED AT 16" O.C. (TYP FOR OPENINGS GREATER THAN 10'-0").
 - ALL HEADERS WHERE BRICK IS PRESENT, TO BE ① (UNO).

SHADED WALLS INDICATED LOAD BEARING WALLS

NOTE: REDUCE JOIST SPACING UNDER TILE FLOORS, GRANITE COUNTERTOPS AND/OR ISLANDS.

NOTE: --- = DESIGNATES JOIST SUPPORTED LOAD BEARING WALL ABOVE. PROVIDE BLOCKING UNDER JOIST SUPPORTED LOAD BEARING WALL.

THESE PLANS ARE DESIGNED IN ACCORDANCE WITH ARCHITECTURAL PLANS PROVIDED BY LGI HOMES COMPLETED/REVISED ON 12/29/2021. IT IS THE RESPONSIBILITY OF THE CLIENT TO NOTIFY SUMMIT ENGINEERING, LABORATORY & TESTING, INC. IF ANY CHANGES ARE MADE TO THE ARCHITECTURAL PLANS PRIOR TO CONSTRUCTION. SUMMIT CANNOT GUARANTEE THE ADEQUACY OF THESE STRUCTURAL PLANS WHEN USED WITH ARCHITECTURAL PLANS DATED DIFFERENTLY THAN THE DATE LISTED ABOVE.

ROOF TRUSS AND FLOOR JOIST LAYOUTS, AND THEIR CORRESPONDING LOADING DETAILS, WERE NOT PROVIDED TO SUMMIT ENGINEERING, LABORATORY & TESTING, INC. (SUMMIT) PRIOR TO THE INITIAL DESIGN. THEREFORE, TRUSS AND JOIST DIRECTIONS WERE ASSUMED BASED ON THE INFORMATION PROVIDED BY LGI HOMES. SUBSEQUENT PLAN REVISIONS BASED ON ROOF TRUSS AND FLOOR JOIST LAYOUTS SHALL BE NOTED IN THE REVISION LIST, INDICATING THE DATE THE LAYOUTS WERE PROVIDED. SHOULD ANY DISCREPANCIES BECOME APPARENT, THE CONTRACTOR SHALL NOTIFY SUMMIT IMMEDIATELY.

STRUCTURAL MEMBERS ONLY

ENGINEERING SEAL APPLIES ONLY TO STRUCTURAL COMPONENTS ON THIS DOCUMENT. SEAL DOES NOT INCLUDE CONSTRUCTION MEANS, METHODS, TECHNIQUES, SEQUENCES, PROCEDURES OR SAFETY PRECAUTIONS. ANY DEVIATIONS OR DISCREPANCIES ON PLANS ARE TO BE BROUGHT TO THE IMMEDIATE ATTENTION OF SUMMIT ENGINEERING, LABORATORY & TESTING, INC. FAILURE TO DO SO WILL VOID SUMMIT LIABILITY.

STRUCTURAL ANALYSIS BASED ON 2018 NCR. C.

FIRST FLOOR FRAMING PLAN

SCALE: 1/8"=1'

NOTE: TRUSS UPLIFT LOADS SHALL BE DETERMINED PER TRUSS MANUFACTURER IN ACCORDANCE WITH SECTION R602.11.11. WALL SHEATHING AND FASTENERS HAVE BEEN DESIGNED TO RESIST THE WIND UPLIFT LOAD PATH IN ACCORDANCE WITH METHOD 3 OF SECTION R602.3.5 OF THE 2018 NCR. REFER TO BRACED WALL PLANS FOR SHEATHING AND FASTENER REQUIREMENTS.

NOTE: 1ST PLY OF ALL SHOWN GIRDER TRUSSES TO ALIGN WITH INSIDE FACE OF WALL (TYP, UNO)

NOTE: ROOF TRUSSES SHALL BE SPACED TO SUPPORT FALSE FRAMED DORMER WALLS (TYP, UNO)

REFER TO DETAIL 4/D61 FOR EYEBROW RETURN OR SHED ROOF FRAMING REQUIREMENTS. (TYP FOR ROOFS PROTRUDING MAXIMUM 24" FROM STRUCTURE)

NOTE: OVERFRAMING PER ROOF TRUSS MANUF. OR AS FOLLOWS:
- MIN 2x6 RAFTERS @ 24" O.C. FOR SPANS UP TO 11'-0"
- MIN 2x8 RAFTERS @ 24" O.C. FOR SPANS UP TO 13'-11"
- MIN 2x10 RAFTERS @ 24" O.C. FOR SPANS UP TO 16'-6"
- RIDGES SHALL BE ONE DIMENSION LUMBER SIZE LARGER THAN OPPOSING RAFTERS.
- RAFTERS SHALL BE SECURED TO RIDGE W/ MIN. (2) 16d NAILS.
- RAFTERS SHALL BEAR ON 2x10 FLAT PLATE VALLEY. VALLEY SHALL BE SECURED TO EACH ROOF TRUSS W/ (2) 16d NAILS.
- RAFTERS SHALL BE SECURED TO PLATE W/ MIN. (3) 8d NAILS.
- SPANS ARE BASED ON HORIZ. PROJECTED RAFTER LENGTH.

TRUSS UPLIFT CONNECTOR SCHEDULE			
MAX. UPLIFT	ROOF TO WALL	FLOOR TO FLOOR	FLOOR TO FND
6000 LBS	H2.5A	PER WALL SHEATHING & FASTENERS	
1000 LBS	(2) H2.5A	C5/6 (END + 1")	DTT2Z
1450 LBS	HT510	C5/6 (END + 1")	DTT2Z
2000 LBS	(2) HT510	(2) C5/6 (END + 1")	DTT2Z
2900 LBS	(2) HT510	(2) C5/6 (END + 1")	HTT4
3685 LBS	LG13-SD625	M5TC52	HTT4

1. ALL PRODUCTS LISTED ARE SIMPSON STRONG-TIE EQUIVALENT PRODUCTS MAY BE USED PER MANUFACTURER'S SPECIFICATIONS.
2. UPLIFT VALUES LISTED ARE FOR 5/16" #2 GRADE MEMBERS AND INCLUDE ADDITIONAL WITHDRAWAL STRENGTH FROM REQUIRED TRUSS TO TOP PLATE TOE NAILING PER CHAPTER 6 OF THE NCR.
3. REFER TO TRUSS LAYOUT PER MANUFACTURER FOR UPLIFT VALUES AND TRUSS TO TRUSS CONNECTIONS. CONNECTORS SPECIFIED BY TRUSS MANUFACTURER OVERRIDE THOSE LISTED ABOVE.
4. TRUSS MANUFACTURER IS RESPONSIBLE FOR VERIFYING CONNECTORS SATISFIES ALL TRUSS BEARING REQUIREMENTS.
5. CONTACT SUMMIT FOR REQUIRED CONNECTORS WHEN LOADS EXCEED THOSE LISTED ABOVE.

HEADER SCHEDULE		
TAG	SIZE	JACKS (EACH END)
A	(2) 2x6	(1)
B	(2) 2x8	(2)
C	(2) 2x10	(2)
D	(2) 2x12	(2)
E	(2) 3-1/4" LSL/LVL	(3)
F	(2) 11-1/8" LSL/LVL	(3)
G	(3) 2x8	(2)
H	(3) 2x10	(2)
I	(3) 2x12	(2)

- NOTES:**
- HEADER SIZES SHOWN ON PLANS ARE MINIMUMS. GREATER HEADER SIZES MAY BE USED FOR EASE OF CONSTRUCTION.
 - ALL HEADERS TO BE DROPPED (UNO).
 - STUD COLUMNS NOTED ON PLAN OVERRIDE STUD COLUMNS LISTED ABOVE (UNO).

KING STUD SCHEDULE	
MAXIMUM HEADER SPAN	MINIMUM KING STUDS E.E.
3'-0"	(1)
4'-0"	(2)
8'-0"	(3)
12'-0"	(5)
16'-0"	(6)

KING STUD REQUIREMENT LISTED ABOVE DO NOT APPLY TO OPENING WHERE PORTAL FRAME IS SPECIFIED

BEAM SCHEDULE	
TAG	SIZE
B1	(1) 11-1/8" FLOOR JOIST OR FLOOR TRUSS
B2	(2) 11-1/8" FLOOR JOIST OR FLOOR TRUSS
B3	(1) 14" FLOOR JOIST OR FLOOR TRUSS
B4	(2) 14" FLOOR JOIST OR FLOOR TRUSS
B5	(1) 9-1/4" LSL/LVL
B6	(2) 9-1/4" LSL/LVL
B7	(1) 11-1/8" LSL/LVL
B8	(2) 11-1/8" LSL/LVL
B9	(1) 14" LSL/LVL
B10	(2) 14" LSL/LVL
B11	(2) 2x10

NOTES:

- BEAM SIZES SHOWN ON PLANS ARE MINIMUMS. LARGER BEAM SIZES MAY BE USED FOR EASE OF CONSTRUCTION.
- BEAMS ARE TO BE SET TOP FLUSH W/ FLOOR SYSTEM (UNO)

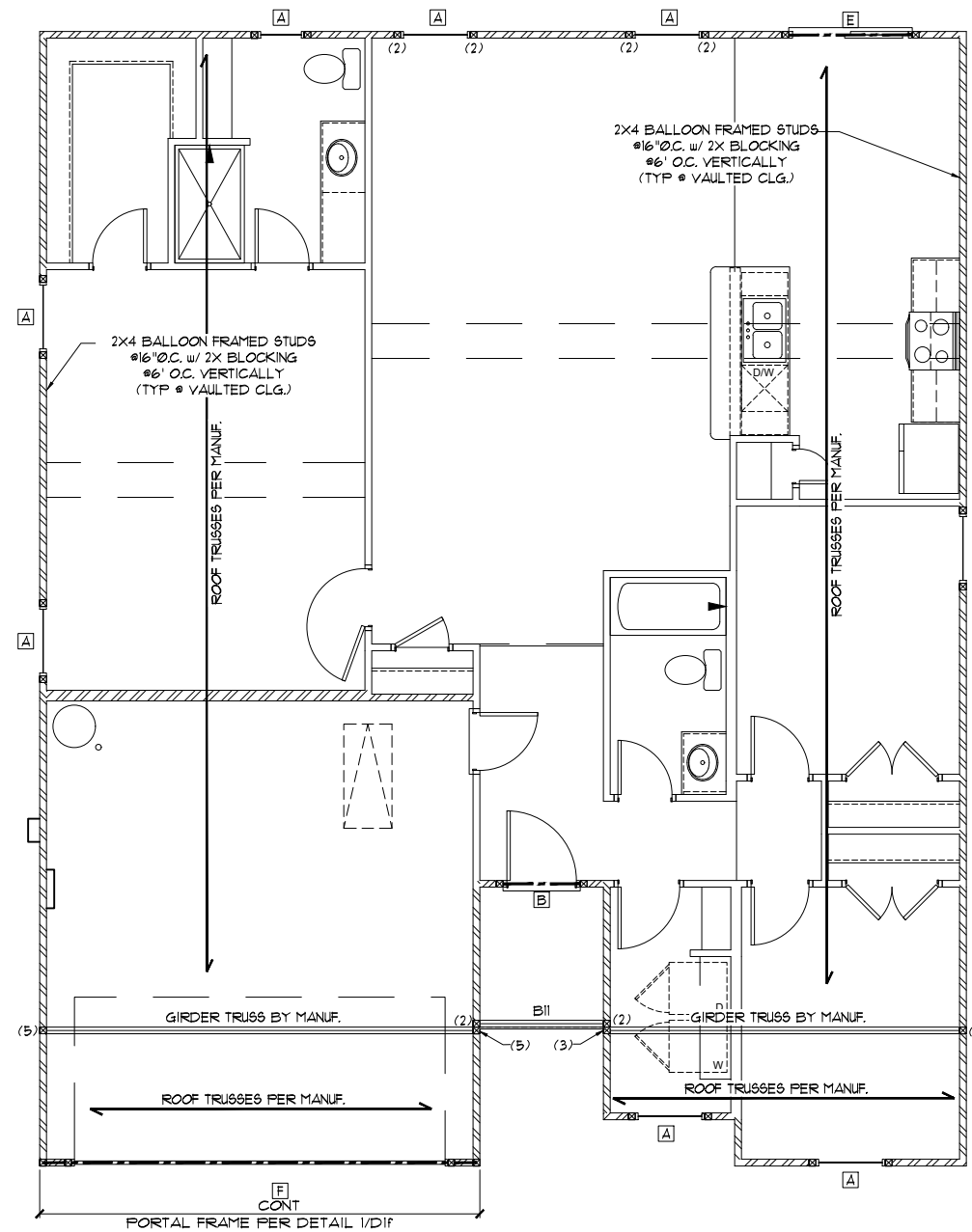

ALL ELEVATIONS - ROOF TRUSSES

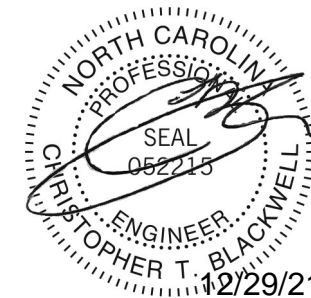

STRUCTURAL MEMBERS ONLY

SUMMIT
ENGINEERING LABORATORY TESTING

3070 HAMMOND BUSINESS PLACE, SUITE 171
RALEIGH, NC 27603
OFFICE: 919.380.9991
FAX: 919.380.9993
WWW.SUMMIT-COMPANIES.COM

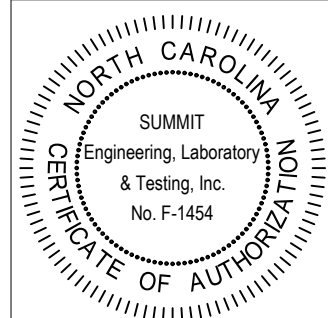

ALEXANDER (LH)
First Floor Framing
LGI Homes
7201 Creedmoor Road, Suite 147
Raleigh, NC 27613

CURRENT DRAWING
DATE: 12/29/2021
SCALE: 1/8"=1'-0"
PROJECT #: 1203-08R: 26545
DRAWN BY: BAF
CHECKED BY: CTB

ORIGINAL DRAWING
DATE PROJECT #
1/29/2020 26545

REFER TO COVER SHEET FOR A COMPLETE LIST OF REVISIONS

SHEET
S3.0

REQUIRED BRACED WALL PANEL CONNECTIONS				
METHOD	MATERIAL	MIN THICKNESS	REQUIRED CONNECTION	
			# PANEL EDGES	# INTERMEDIATE SUPPORTS
CS-WSP	WOOD STRUCTURAL PANEL	3/8"	6d COMMON NAILS # 6" O.C.	6d COMMON NAILS # 12" O.C.
GB	GYPSON BOARD	1/2"	5d COOLER NAILS # 12" O.C.	5d COOLER NAILS # 12" O.C.
WSP	WOOD STRUCTURAL PANEL	3/8"	6d COMMON NAILS # 6" O.C.	6d COMMON NAILS # 12" O.C.
PF	WOOD STRUCTURAL PANEL	1/6"	PER FIGURE R602.10.6.4	PER FIGURE R602.10.6.4

*OR EQUIVALENT PER TABLE R102.3.5

BRACED WALL NOTES:

- WALLS SHALL BE DESIGNED IN ACCORDANCE WITH SECTION R602.10 FROM THE 2015 INTERNATIONAL RESIDENTIAL CODE WITH ALL LOCAL AND STATE AMENDMENTS.
- WALLS ARE DESIGNED FOR SEISMIC ZONES A-C AND ULTIMATE DESIGN WIND SPEEDS UP TO 130 MPH.
- REFER TO ARCHITECTURAL PLAN FOR DOOR/WINDOW OPENING SIZES.
- BRACING MATERIALS, METHODS AND FASTENERS SHALL BE IN ACCORDANCE WITH TABLE R602.10.4.
- ALL BRACED WALL PANELS SHALL BE FULL WALL HEIGHT AND SHALL NOT EXCEED 10 FEET FOR ISOLATED PANEL METHOD AND 12 FEET FOR CONTINUOUS SHEATHING METHOD WITHOUT ADDITIONAL ENGINEERING CALCULATIONS.
- MINIMUM PANEL LENGTH SHALL BE PER TABLE R602.10.5.
- THE INTERIOR SIDE OF EXTERIOR WALLS AND BOTH SIDES OF INTERIOR WALLS SHALL BE SHEATHED CONTINUOUSLY WITH MINIMUM 1/2" GYPSUM BOARD (UNO).
- FOR CONTINUOUS SHEATHING METHOD, EXTERIOR WALLS SHALL BE SHEATHED ON ALL SHEATHABLE SURFACES INCLUDING INFILL AREAS BETWEEN BRACED WALL PANELS ABOVE AND BELOW WALL OPENINGS AND ON GABLE END WALLS.
- FLOORS SHALL NOT BE CANTILEVERED MORE THAN 24" BEYOND THE FOUNDATION OR BEARING WALL BELOW WITHOUT ADDITIONAL ENGINEERING CALCULATIONS.
- A BRACED WALL PANEL SHALL BE LOCATED WITHIN 10 FEET OF EACH END OF A BRACED WALL LINE.
- THE MAXIMUM EDGE DISTANCE BETWEEN BRACED WALL PANELS SHALL NOT EXCEED 20 FEET.
- ADEQUATE CONTINUOUS LOAD PATHS FOR TRANSFER OF BRACING LOADS AND UPLIFT LOADS SHALL COMPLY WITH IRC SECTION R602.3.5.
- MASONRY OR CONCRETE STEM WALLS WITH A LENGTH OF 48" OR LESS SUPPORTING A BRACED WALL PANEL SHALL BE DESIGNED IN ACCORDANCE WITH FIGURE R602.10.9 OF THE 2015 IRC.
- BRACED WALL PANEL CONNECTIONS TO FLOOR/CEILING SHALL BE CONSTRUCTED IN ACCORDANCE WITH SECTION R602.10.8.
- BRACED WALL PANEL CONNECTIONS TO ROOF SHALL BE CONSTRUCTED IN ACCORDANCE WITH SECTION R602.10.2.
- CRIPPLE WALLS AND WALK OUT BASEMENT WALLS SHALL BE DESIGNED IN ACCORDANCE WITH SECTION R602.10.1.
- PORTAL WALLS SHALL BE DESIGNED IN ACCORDANCE WITH FIGURE R602.10.6.4 (UNO).
- ON SCHEMATIC, SHADED WALLS INDICATE BRACED WALL PANELS.
- ABBREVIATIONS:

GB = GYPSUM BOARD WSP = WOOD STRUCTURAL PANEL
 CS-XXX = CONT. SHEATHED ENG = ENGINEERED SOLUTION
 PF = PORTAL FRAME PF-ENG = ENG. PORTAL FRAME

INSTALL HOLD-DOWNS FOR BRACED WALL END CONDITIONS PER SECTION R602.10.8 AND FIGURE R602.10.1 OF THE 2015 IRC.

NOTE: WALL SHEATHING AND FASTENERS HAVE BEEN DESIGNED TO RESIST THE CONTINUOUS WIND UPLIFT LOAD PATH IN ACCORDANCE WITH METHOD 3 OF SECTION R602.3.5 OF THE 2018 NCRS.

THESE PLANS ARE DESIGNED IN ACCORDANCE WITH ARCHITECTURAL PLANS PROVIDED BY LGI HOMES COMPLETED/REVISED ON 12/29/2021. IT IS THE RESPONSIBILITY OF THE CLIENT TO NOTIFY SUMMIT ENGINEERING, LABORATORY & TESTING, INC. IF ANY CHANGES ARE MADE TO THE ARCHITECTURAL PLANS PRIOR TO CONSTRUCTION. SUMMIT CANNOT GUARANTEE THE ADEQUACY OF THESE STRUCTURAL PLANS WHEN USED WITH ARCHITECTURAL PLANS DATED DIFFERENTLY THAN THE DATE LISTED ABOVE.

STRUCTURAL MEMBERS ONLY

ENGINEERING SEAL APPLIES ONLY TO STRUCTURAL COMPONENTS ON THIS DOCUMENT. SEAL DOES NOT INCLUDE CONSTRUCTION MEANS, METHODS, TECHNIQUES, SEQUENCES, PROCEDURES OR SAFETY PRECAUTIONS. ANY DEVIATIONS OR DISCREPANCIES ON PLANS ARE TO BE BROUGHT TO THE IMMEDIATE ATTENTION OF SUMMIT ENGINEERING, LABORATORY & TESTING, INC. FAILURE TO DO SO WILL VOID SUMMIT LIABILITY.

STRUCTURAL ANALYSIS BASED ON 2018 NCRS.

FIRST FLOOR BRACING PLAN

SCALE: 1/8"=1'

FIRST FLOOR BRACING (FT)		
	CONTINUOUS SHEATHING METHOD	
	REQUIRED	PROVIDED
BWL 1-1	1.8	26.1
BWL 1-2	1.8	11.5
BWL 1-A	6.4	42.9
BWL 1-B	6.4	46.0

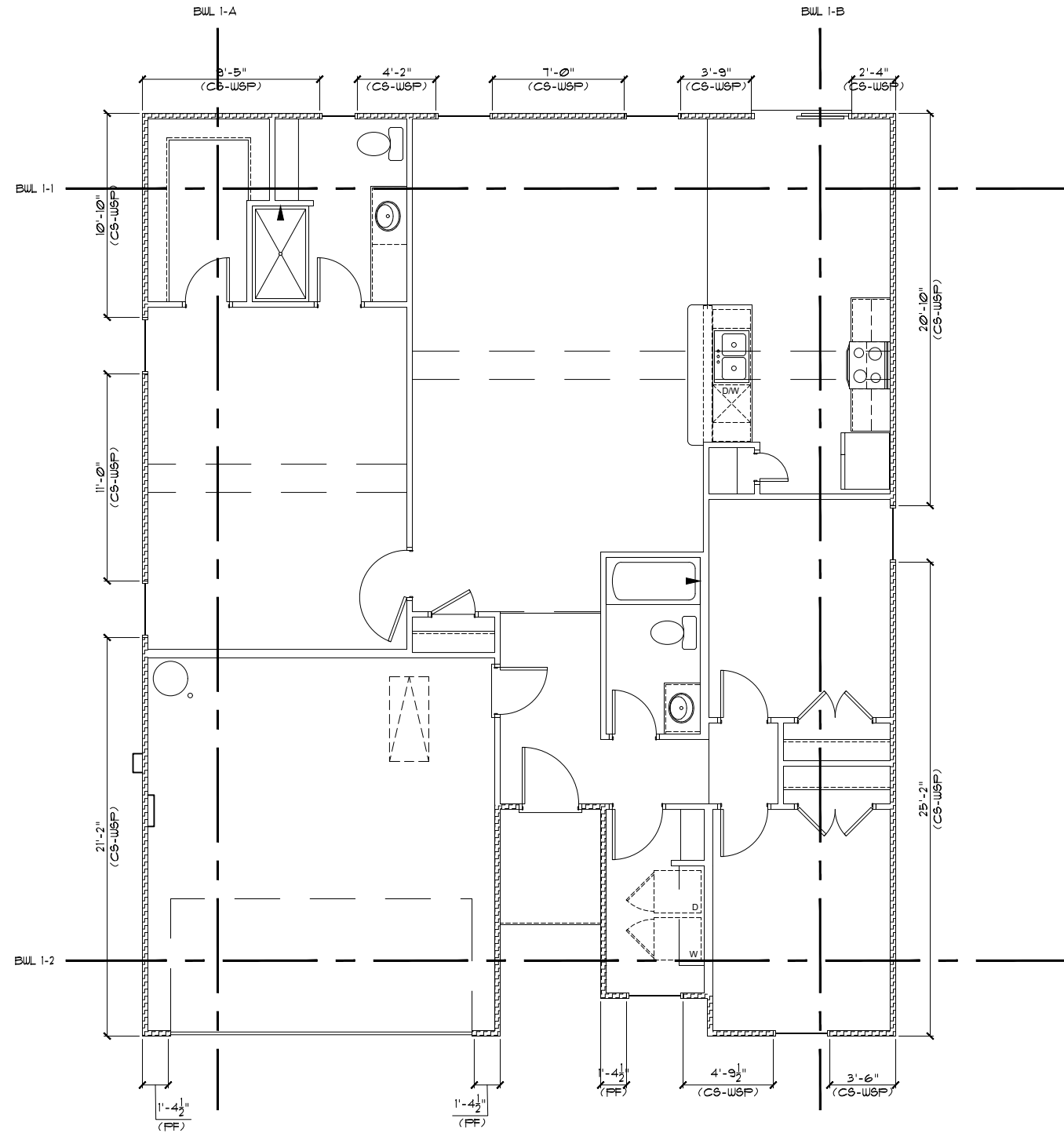

ALL ELEVATIONS

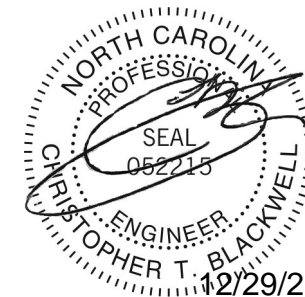

STRUCTURAL MEMBERS ONLY

SUMMIT
 ENGINEERING LABORATORY TESTING
 3070 HAMMOND BUSINESS PLACE, SUITE 171
 RALEIGH, NC 27603
 OFFICE: 919.380.9991
 FAX: 919.380.9993
 WWW.SUMMIT-COMPANIES.COM

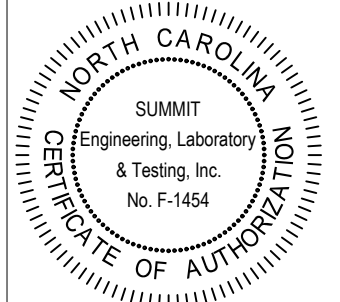

ALEXANDER (LH)
 First Floor Bracing
 LGI Homes
 7201 Creedmoor Road, Suite 147
 Raleigh, NC 27613

CURRENT DRAWING
 DATE: 12/29/2021
 SCALE: 1/8"=1'-0"
 PROJECT #: 1203-08R: 26545
 DRAWN BY: BAF
 CHECKED BY: CTB

ORIGINAL DRAWING
 DATE: 1/29/2020 PROJECT #: 26545

REFER TO COVER SHEET FOR A COMPLETE LIST OF REVISIONS

SHEET

S7.0

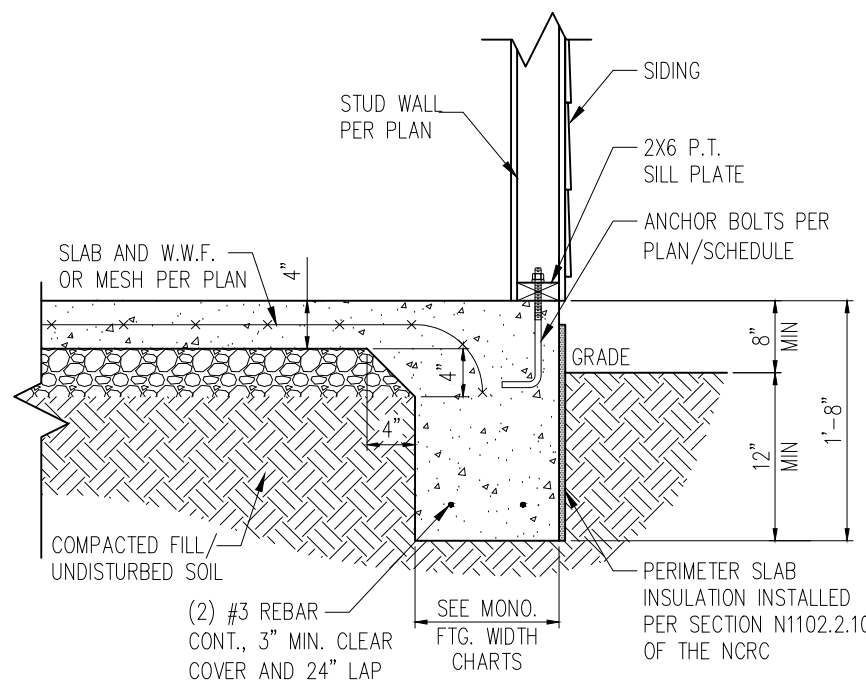

STANDARD - SIDING

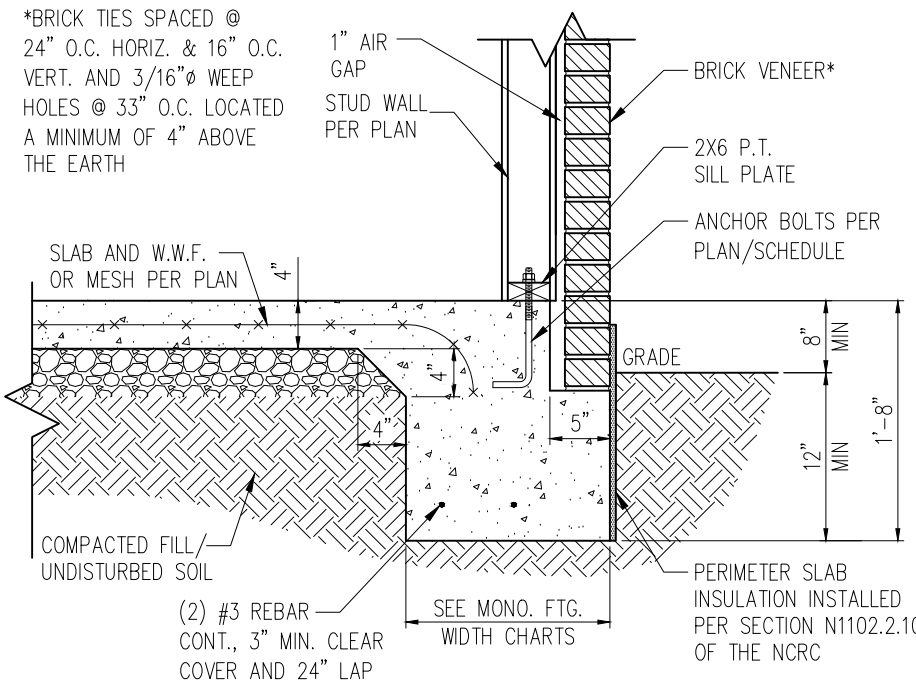

STANDARD - BRICK

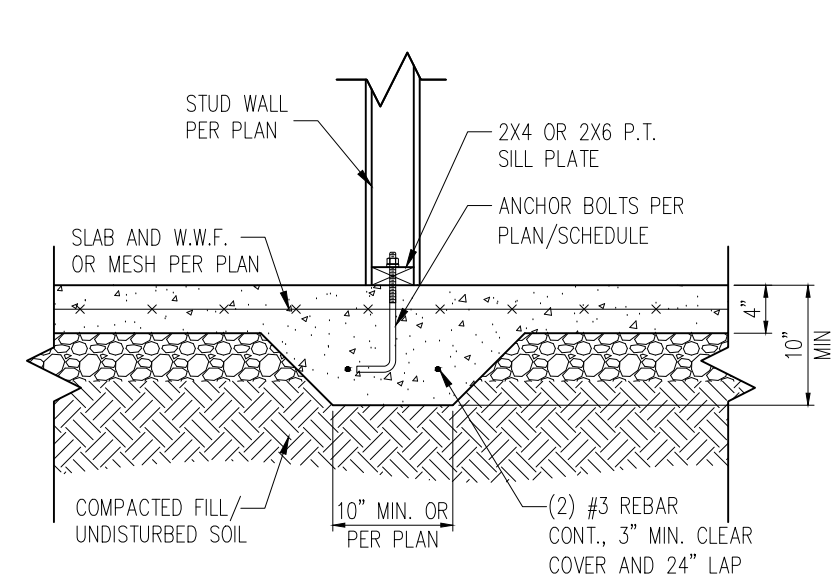

3 TYP. THICKENED SLAB DETAIL
D1m 3/4" = 1'-0"

1 TYP. SLAB DETAIL
D1m 3/4" = 1'-0"

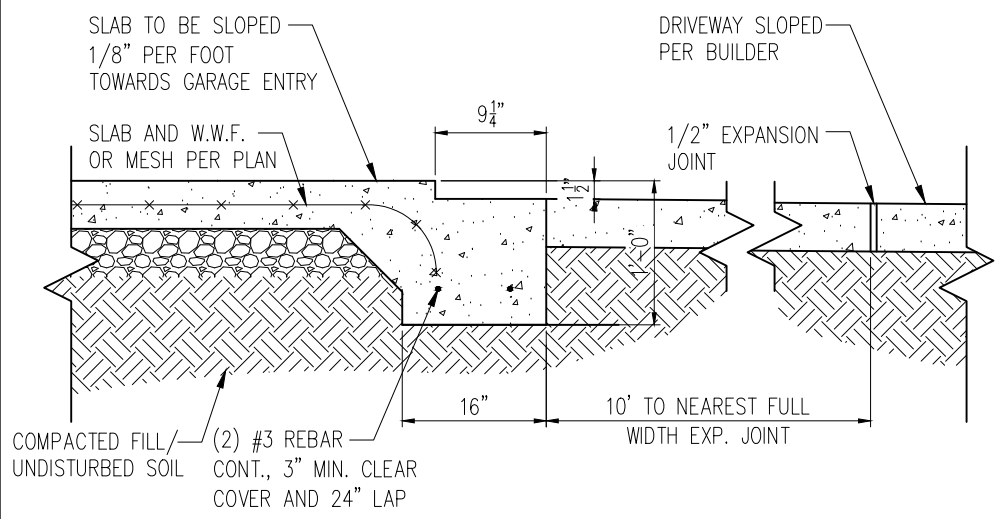

2 SLAB AT GARAGE DOOR
D1m 3/4" = 1'-0"

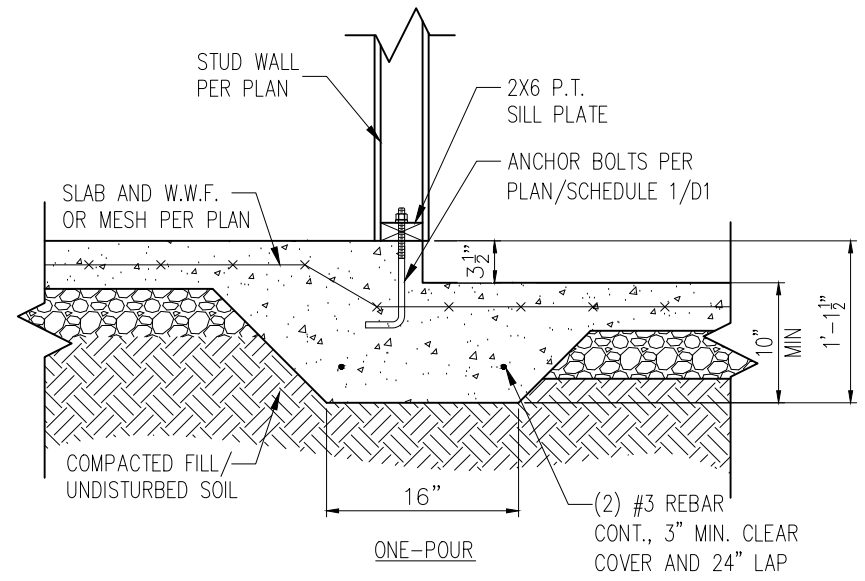

4 STEP IN GARAGE
D1m 3/4" = 1'-0"

WALL ANCHOR SCHEDULE

TYPE OF ANCHOR	MIN. CONC. EMBEDMENT	SPACING EMBEDMENT	INTERIOR WALL	EXTERIOR WALL
1/2"Ø A307 BOLTS w/ STD. 90° BEND	7"	6'-0"	YES	YES
SST - MASA	4"	6'-0"	NO	YES
1/2"Ø THREADED ROD w/ w/ SST SET-XP EPOXY	7"	6'-0"	YES	YES
1/2"Ø SST TITEN HD	4-1/4"	6'-0"	YES	YES

NOTE:
1) INSTALL ALL ANCHORS 12" MAX. FROM ALL BOTTOM PLATE ENDS AND JOINTS.
2) EQUIVALENT ANCHORS MAY BE USED. SIZE & SPACING PER MANUF. SPECS.

MONOLITHIC FOOTING WIDTH

# OF STORIES	WIDTH BASED ON SOIL BEARING CAPACITY		
	1500 PSF	2000 PSF	2500 PSF
1 STORY - STD.	16"	16"	16"
1 STORY - BRICK VENEER	21"*	21"*	21"*
2 STORY - STD.	16"	16"	16"
2 STORY - BRICK VENEER	21"*	21"*	21"*
3 STORY - STD.	23"	18"	18"
3 STORY - BRICK VENEER	32"*	24"*	24"*

*5" BRICK LEDGE HAS BEEN ADDED TO THE MONOLITHIC FOOTING WIDTH FOR BRICK SUPPORT

NOTES:
1. REFER TO GENERAL NOTES & SPECIFICATIONS ON SHEET CS2 FOR ADDITIONAL INFORMATION.
2. PROVIDE 6 MIL VAPOR BARRIER UNDER ALL SLABS-ON-GRADE.
3. SEE ARCH. DWGS. FOR ALL TOP OF THE SLAB ELEVATIONS, SLOPES AND DEPRESSIONS.

3070 HAMMOND BUSINESS PLACE, SUITE 171
RALEIGH, NC 27603
OFFICE: 919.380.9991
FAX: 919.380.9993
WWW.SUMMIT-COMPANIES.COM

PROJECT
Standard Details
Monolithic Slab Details
CLIENT
LGI Homes
3037 Sherman Drive
Lancaster, SC 29720

CURRENT DRAWING
DATE: 10/05/21
SCALE: NTS
PROJECT #: 3554.T0040
DRAWN BY: MSB
CHECKED BY: CTB

ORIGINAL DRAWING
DATE 10/01/19 PROJECT # 24512

REFER TO COVER SHEET FOR A COMPLETE LIST OF REVISIONS

STRUCTURAL MEMBERS ONLY

SHEET
D1m

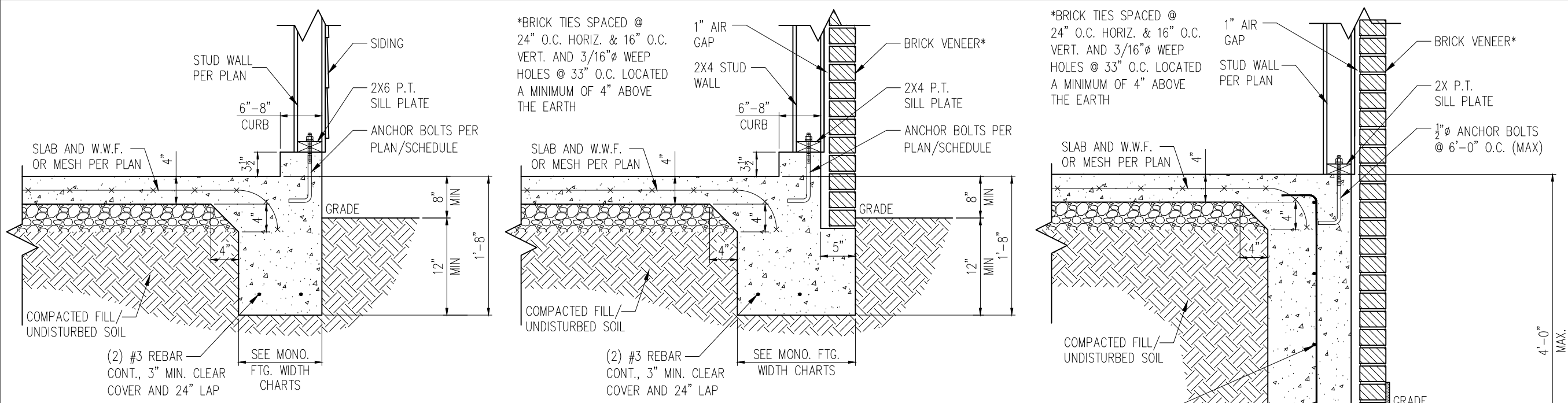

STANDARD - SIDING

STANDARD - BRICK

1 TYP. GARAGE CURB DETAIL
 D2m 3/4" = 1'-0"

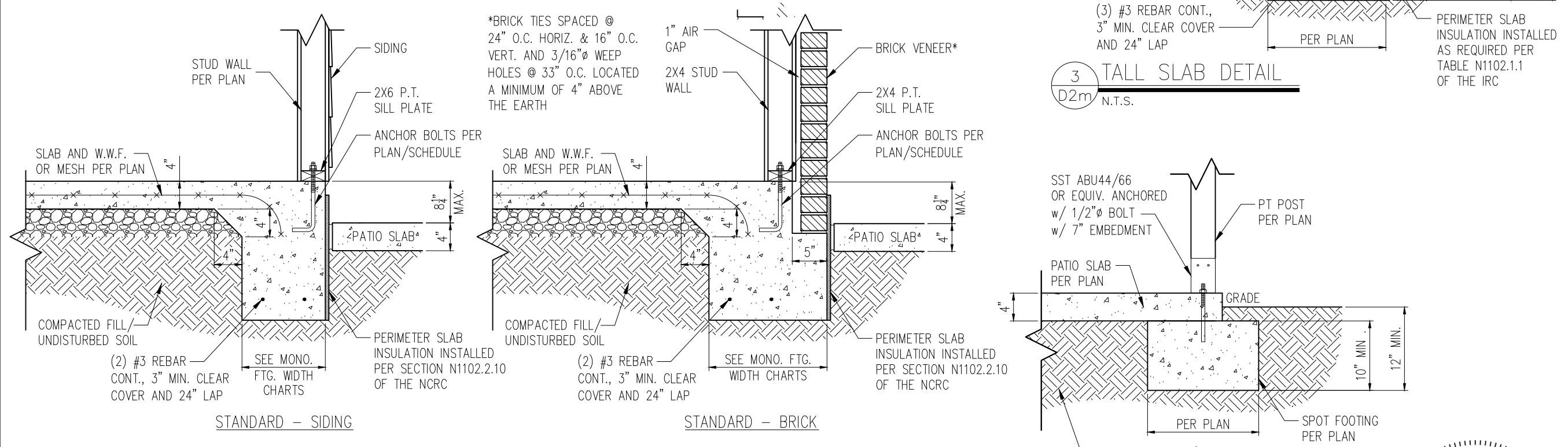

STANDARD - SIDING

STANDARD - BRICK

2 PATIO SLAB DETAIL
 D2m 3/4" = 1'-0"

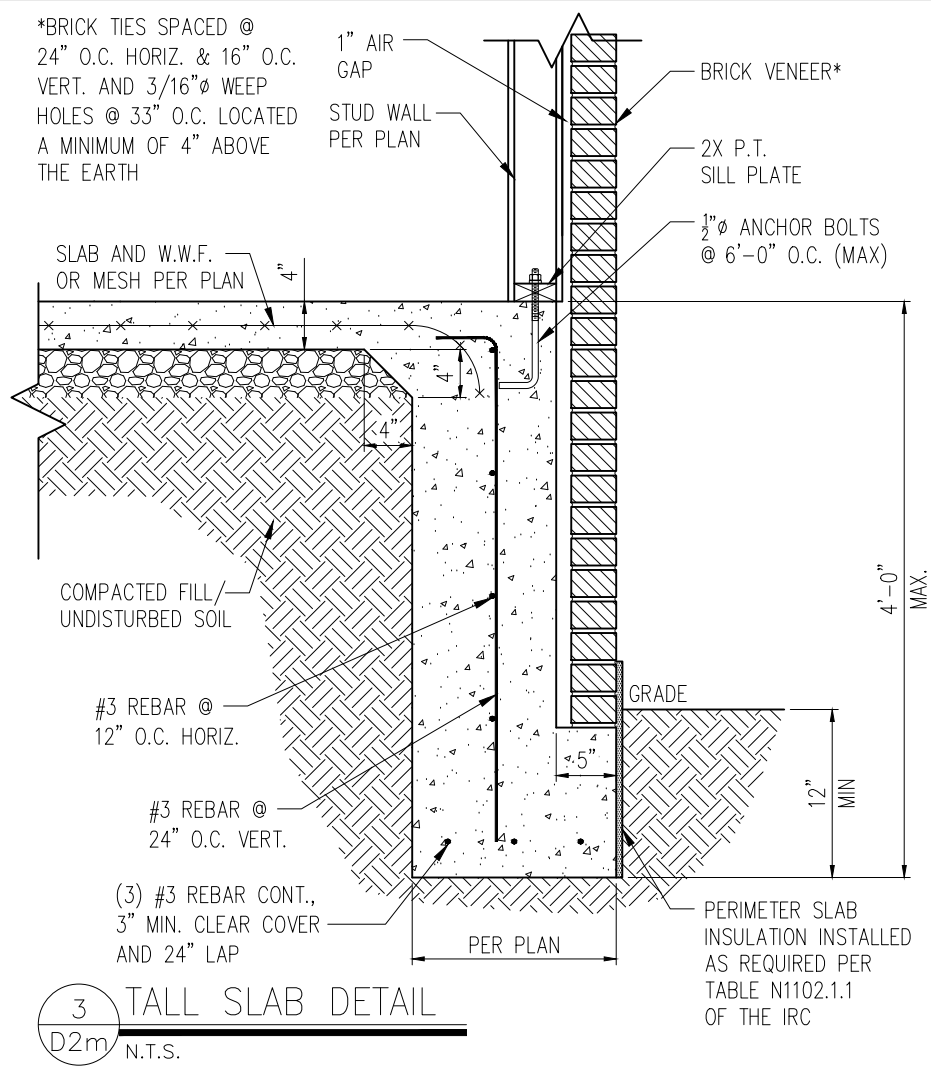

3 TALL SLAB DETAIL
 D2m N.T.S.

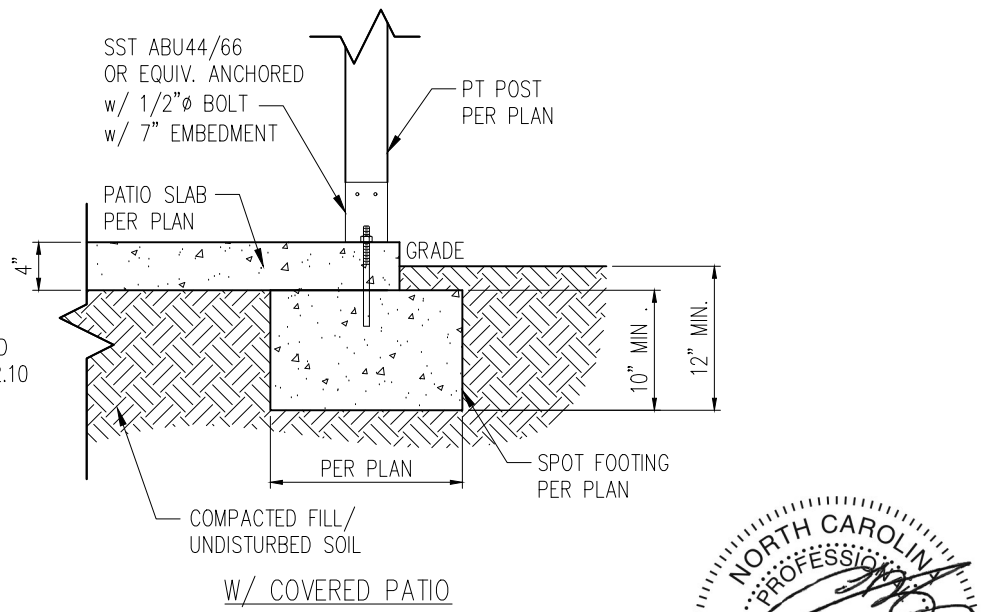

W/ COVERED PATIO

- NOTES:
- REFER TO GENERAL NOTES & SPECIFICATIONS ON SHEET CS2 FOR ADDITIONAL INFORMATION.
 - PROVIDE 6 MIL VAPOR BARRIER UNDER ALL SLABS-ON-GRADE.
 - SEE ARCH. DWGS. FOR ALL TOP OF THE SLAB ELEVATIONS, SLOPES AND DEPRESSIONS.

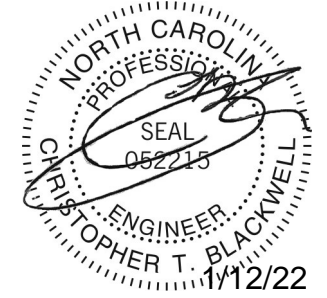

STRUCTURAL MEMBERS ONLY

SUMMIT
 ENGINEERING LABORATORY TESTING
 3070 HAMMOND BUSINESS PLACE, SUITE 171
 RALEIGH, NC 27603
 OFFICE: 919.380.9991
 FAX: 919.380.9993
 WWW.SUMMIT-COMPANIES.COM

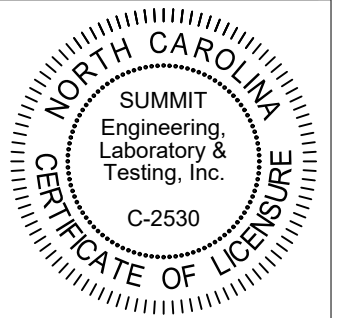

PROJECT
Standard Details
Monolithic Slab Details
 CLIENT
LGI Homes
3037 Sherman Drive
Lancaster, SC 29720

CURRENT DRAWING
 DATE: 10/05/21
 SCALE: NTS
 PROJECT #: 3554.T0040
 DRAWN BY: MSB
 CHECKED BY: CTB

ORIGINAL DRAWING
 DATE: 10/01/19 PROJECT #: 24512

REFER TO COVER SHEET FOR A COMPLETE LIST OF REVISIONS

SHEET
D2m

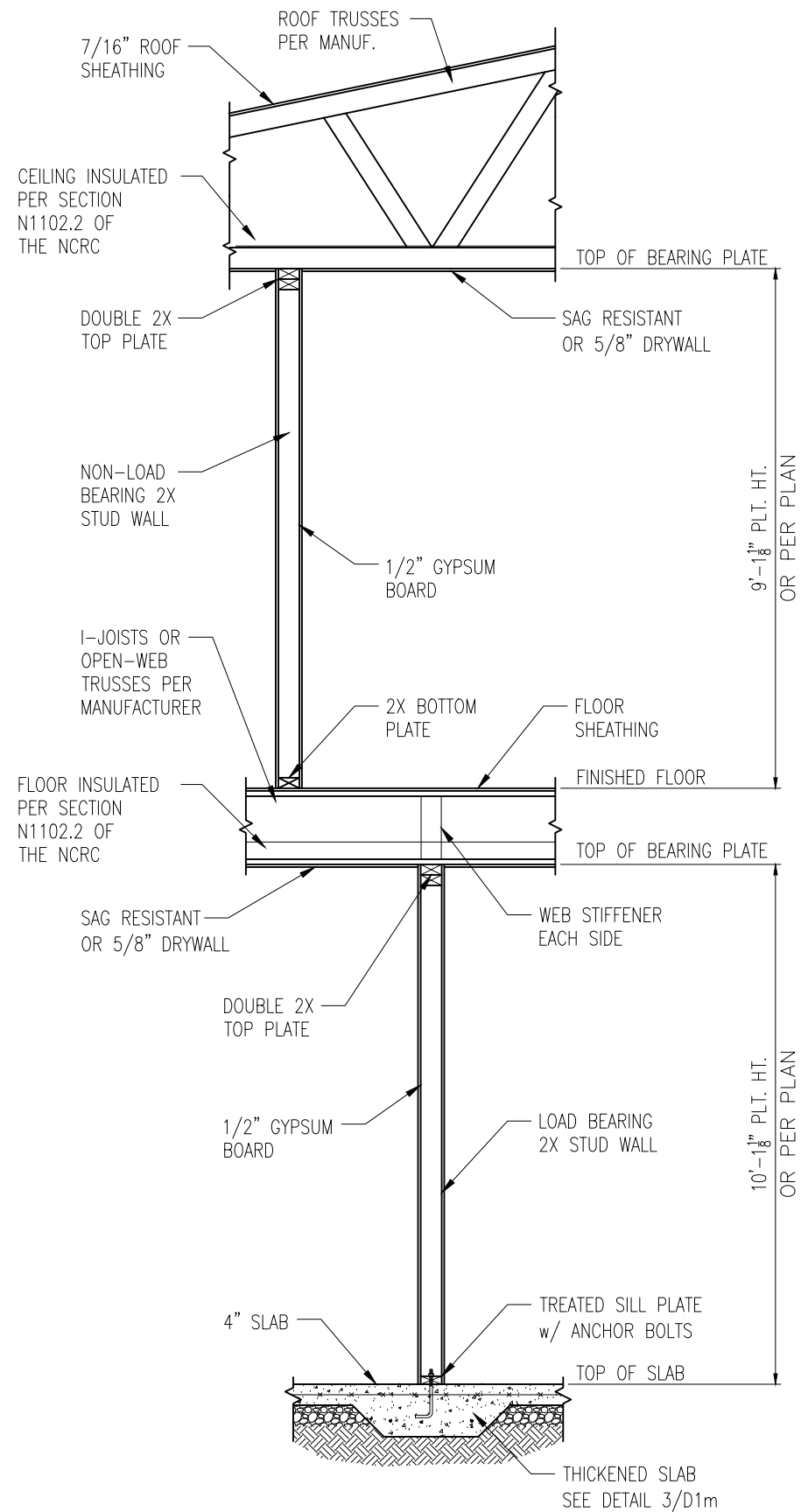

1 TYP. INTERIOR LOAD BEARING WALL SECTION
 D3m 3/4" = 1'-0"

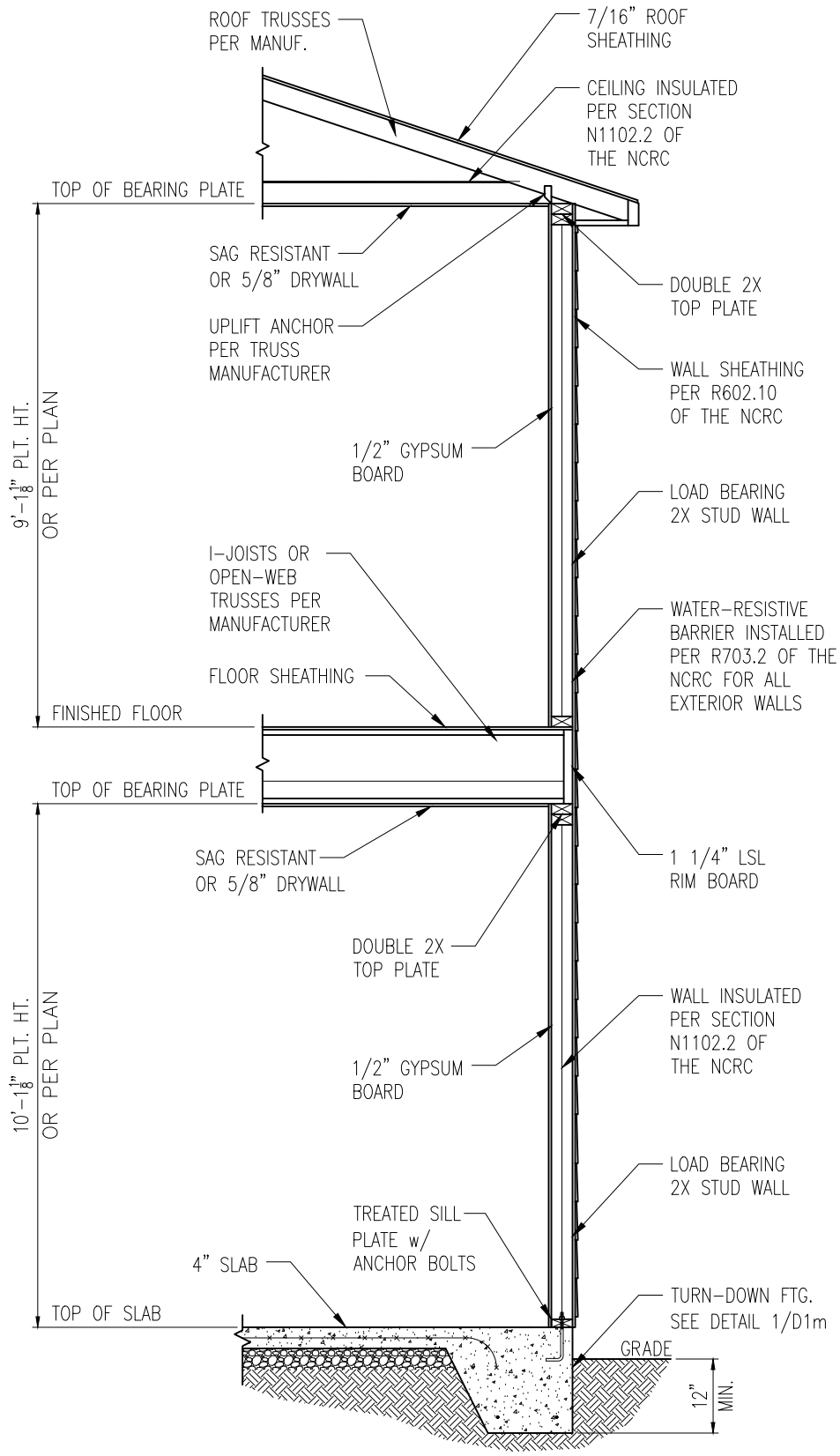

2 TYP. EXTERIOR LOAD BEARING WALL SECTION
 D3m 3/4" = 1'-0"
 -SIMILAR w/ BRICK AND STONE
 -BRICK TIES SPACED @ 24" O.C. HORIZ. & 16" O.C. VERT.
 -MIN. 3/16"Ø WEEP HOLES @ 33" O.C.

- NOTES:
1. REFER TO GENERAL NOTES & SPECIFICATIONS ON SHEET CS2 FOR ADDITIONAL INFORMATION.
 2. PROVIDE 6 MIL VAPOR BARRIER UNDER ALL SLABS-ON-GRADE.
 3. SEE ARCH. DWGS. FOR ALL TOP OF THE SLAB ELEVATIONS, SLOPES AND DEPRESSIONS.

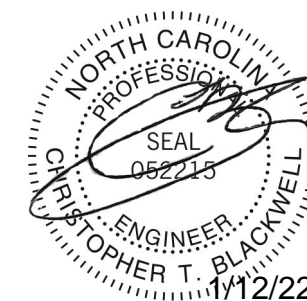

STRUCTURAL MEMBERS ONLY

SUMMIT
 ENGINEERING LABORATORY TESTING
 3070 HAMMOND BUSINESS PLACE, SUITE 171
 RALEIGH, NC 27603
 OFFICE: 919.380.9991
 FAX: 919.380.9993
 WWW.SUMMIT-COMPANIES.COM

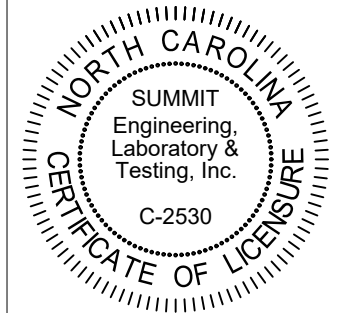

PROJECT
Standard Details
Monolithic Slab Details
 CLIENT
LGI Homes
 3037 Sherman Drive
 Lancaster, SC 29720

CURRENT DRAWING
 DATE: 10/05/21
 SCALE: NTS
 PROJECT #: 3554.T0040
 DRAWN BY: MSB
 CHECKED BY: CTB

ORIGINAL DRAWING
 DATE: 10/01/19 PROJECT #: 24512

REFER TO COVER SHEET FOR A COMPLETE LIST OF REVISIONS

SHEET
D3m

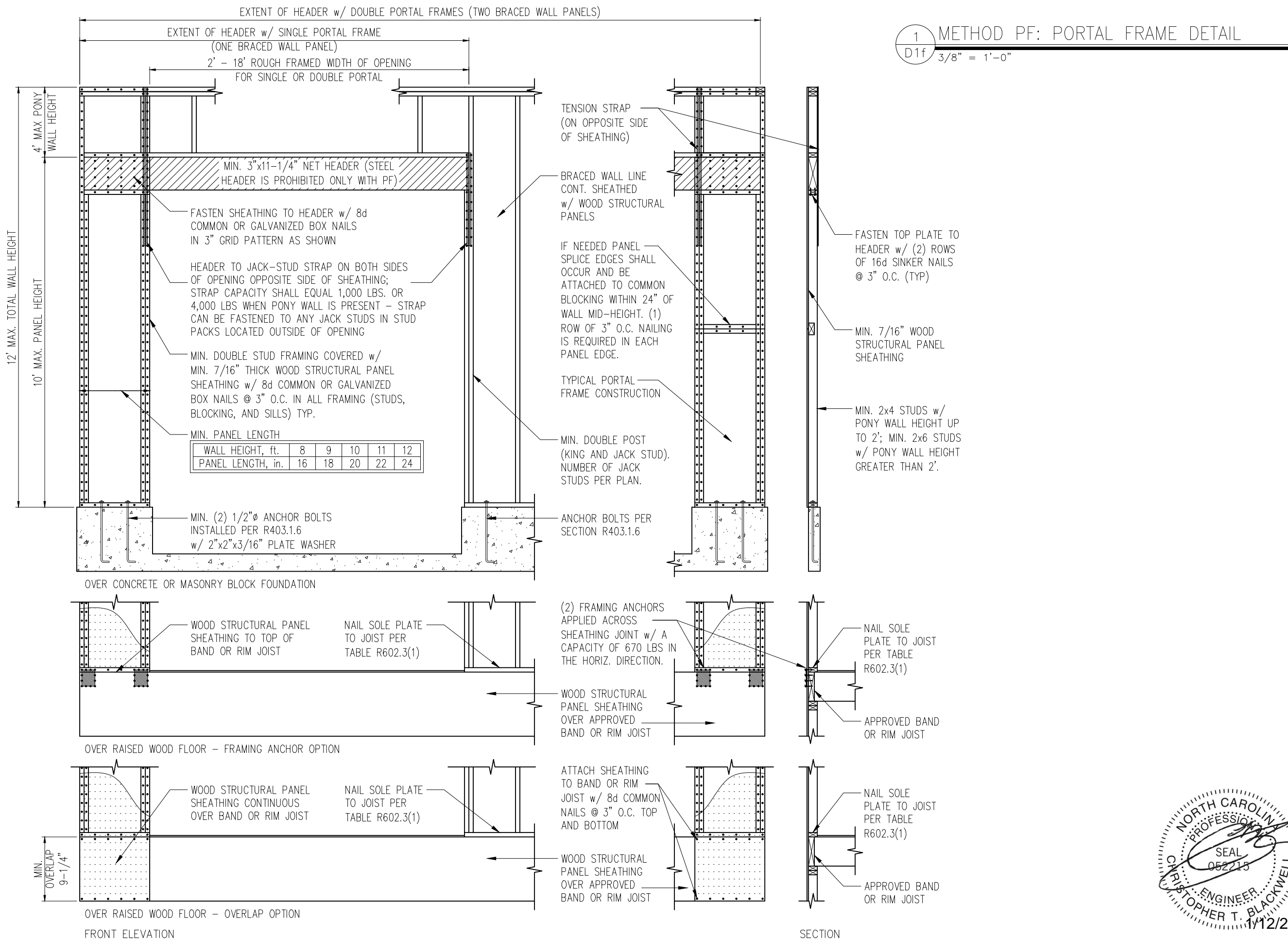

SUMMIT
ENGINEERING LABORATORY TESTING
3070 HAMMOND BUSINESS PLACE, SUITE 171
RALEIGH, NC 27603
OFFICE: 919.380.9991
FAX: 919.380.9993
WWW.SUMMIT-COMPANIES.COM

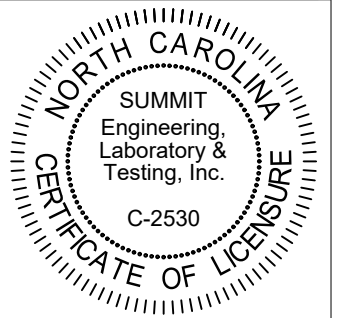

PROJECT
Standard Details
Framing Details
CLIENT
LGI Homes
3037 Sherman Drive
Lancaster, SC 29720

CURRENT DRAWING
DATE: 10/05/21
SCALE: NTS
PROJECT #: 3554.T0040
DRAWN BY: MSB
CHECKED BY: CTB

ORIGINAL DRAWING
DATE: 10/01/19 PROJECT #: 24512

REFER TO COVER SHEET FOR A COMPLETE LIST OF REVISIONS

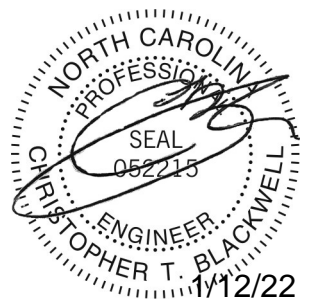

STRUCTURAL MEMBERS ONLY

SHEET
D1f

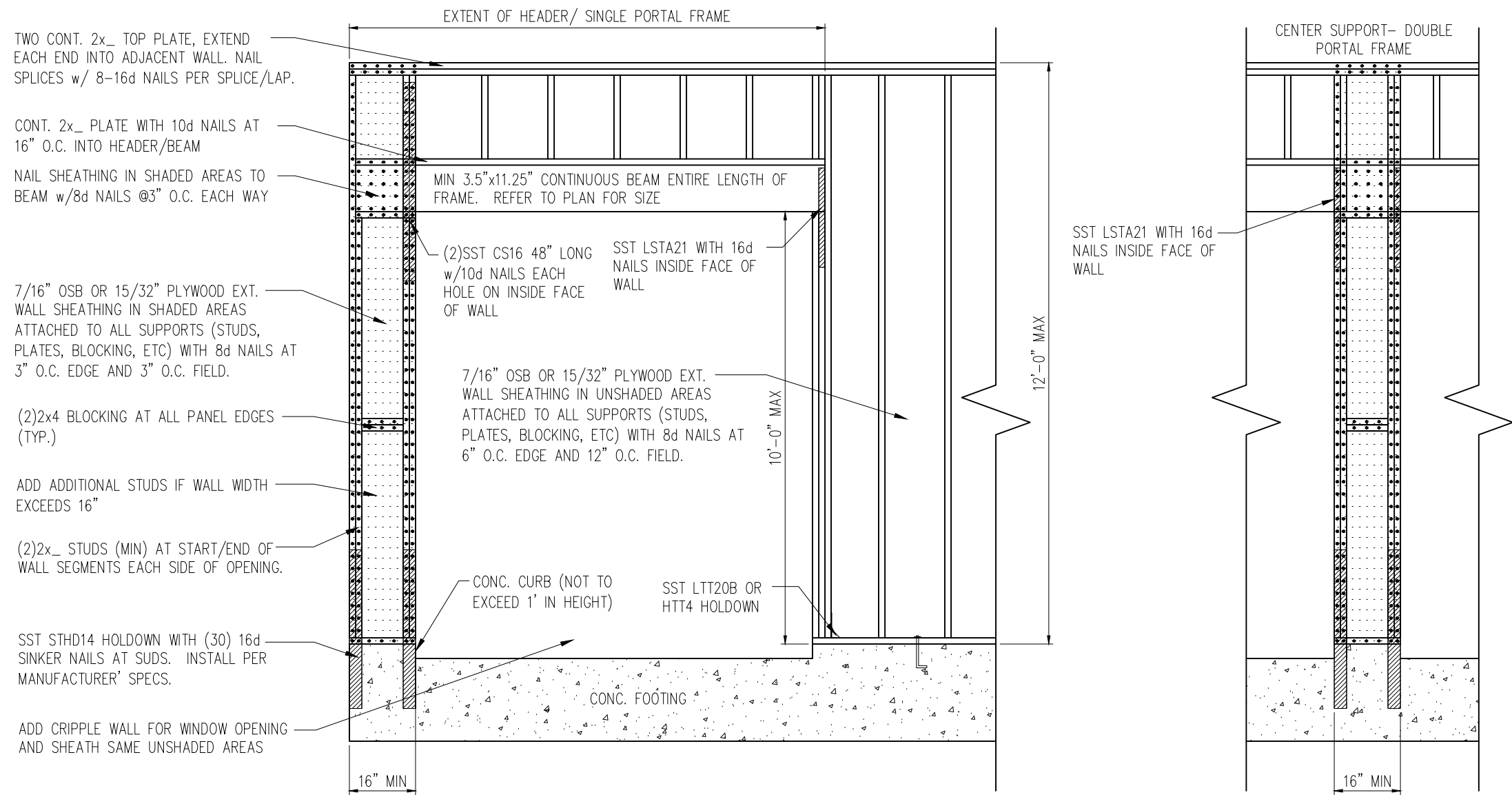

1 METHOD PF: PORTAL FRAME DETAIL w/ HOLD-DOWNS
 D2f 3/4" = 1'-0"

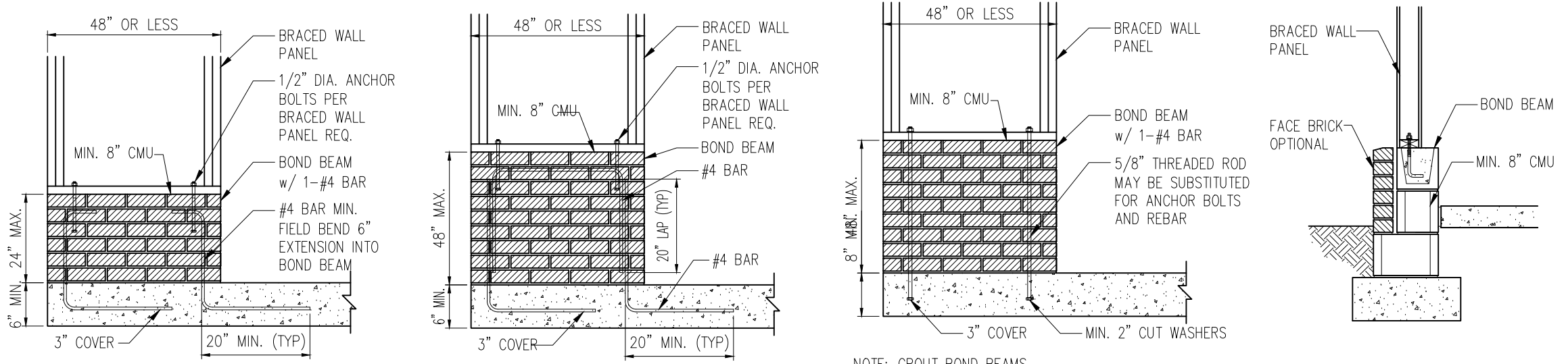

2 MASONRY STEM WALLS SUPPORTING BRACED WALL PANELS
 D2f NTS

NOTE: GROUT BOND BEAMS AND ALL CELLS WHICH CONTAIN REBAR, THREADED RODS AND ANCHOR BOLTS

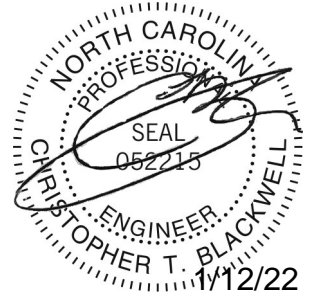

STRUCTURAL MEMBERS ONLY

SUMMIT
 ENGINEERING LABORATORY TESTING
 3070 HAMMOND BUSINESS PLACE, SUITE 171
 RALEIGH, NC 27603
 OFFICE: 919.380.9991
 FAX: 919.380.9993
 WWW.SUMMIT-COMPANIES.COM

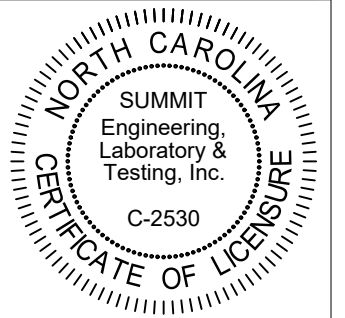

PROJECT
Standard Details - Bracing
Framing Details - Bracing
 CLIENT
LGI Homes
3037 Sherman Drive
Lancaster, SC 29720

CURRENT DRAWING
 DATE: 10/05/21
 SCALE: NTS
 PROJECT #: 3554.T0040
 DRAWN BY: MSB
 CHECKED BY: CTB

ORIGINAL DRAWING
 DATE: 10/01/19 PROJECT #: 24512

REFER TO COVER SHEET FOR A COMPLETE LIST OF REVISIONS

SHEET
D2f

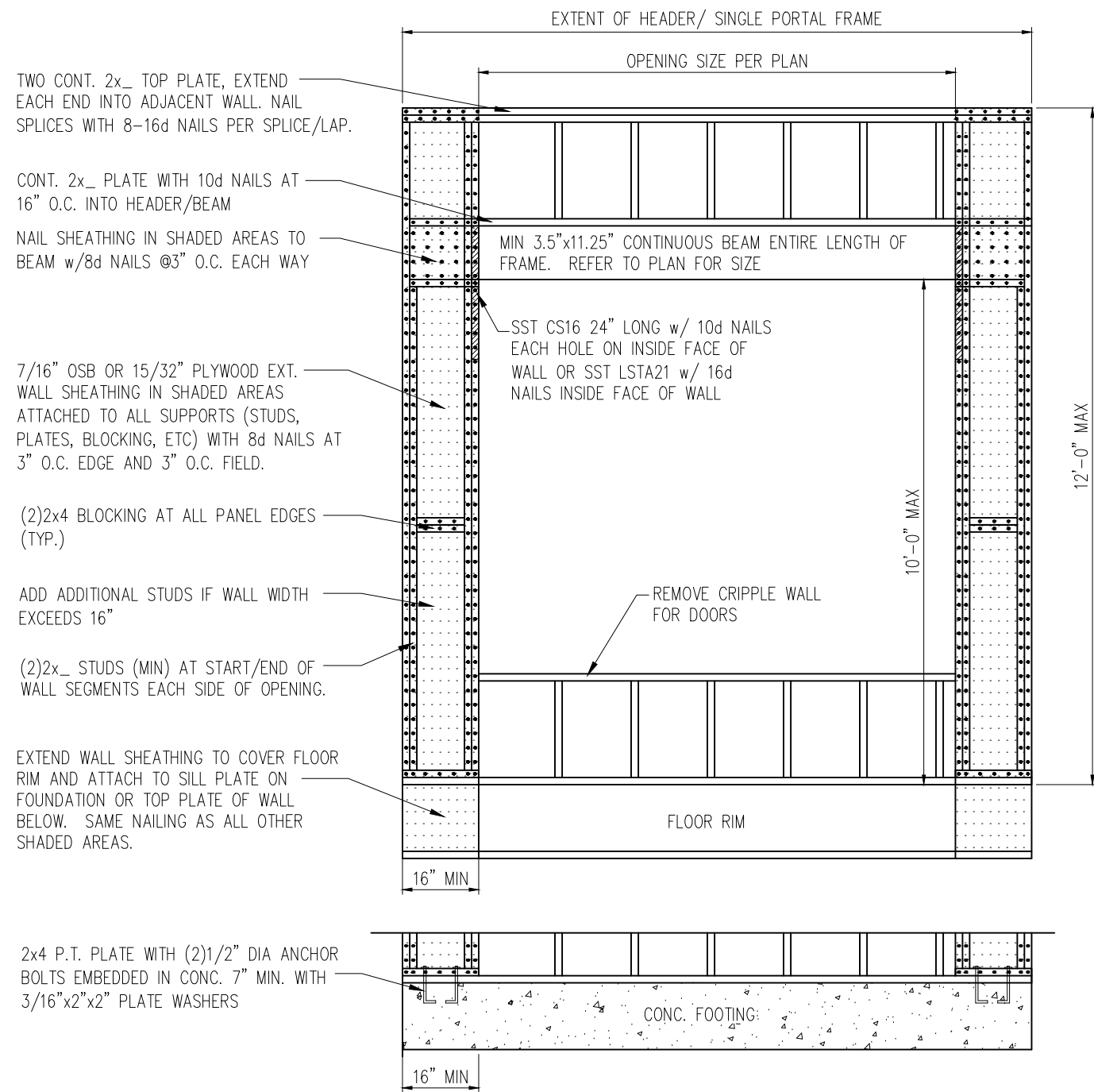

1 METHOD PF: PORTAL FRAME DETAIL
 D3f 3/4" = 1'-0" OPENINGS UNDER 8'-0"

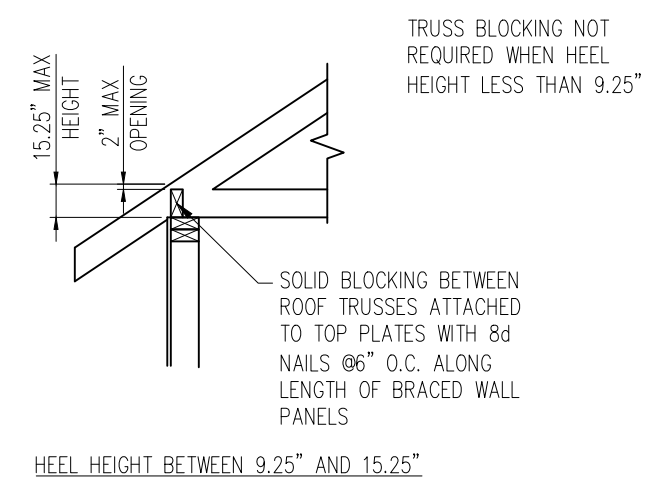
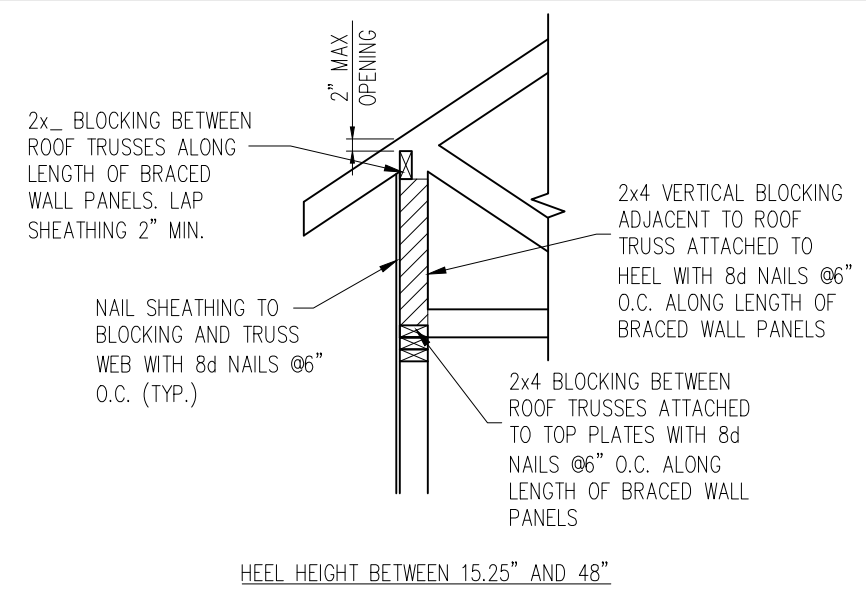

2 TYP. WALL PANEL TO ROOF TRUSS CONNECTION
 D3f 1" = 1'-0"

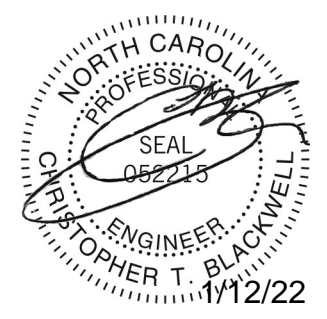

STRUCTURAL MEMBERS ONLY

SUMMIT
 ENGINEERING LABORATORY TESTING
 3070 HAMMOND BUSINESS PLACE, SUITE 171
 RALEIGH, NC 27603
 OFFICE: 919.380.9991
 FAX: 919.380.9993
 WWW.SUMMIT-COMPANIES.COM

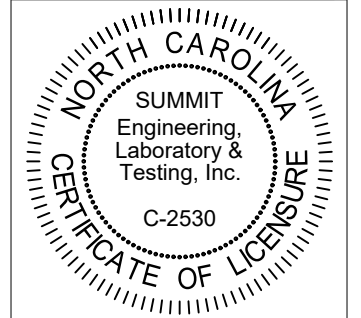

PROJECT
Standard Details
Framing Details - Bracing

CLIENT
LGI Homes
3037 Sherman Drive
Lancaster, SC 29720

CURRENT DRAWING
 DATE: 10/05/21
 SCALE: NTS
 PROJECT #: 3554.T0040
 DRAWN BY: MSB
 CHECKED BY: CTB

ORIGINAL DRAWING
 DATE: 10/01/19 PROJECT #: 24512

REFER TO COVER SHEET FOR A COMPLETE LIST OF REVISIONS

SHEET
D3f

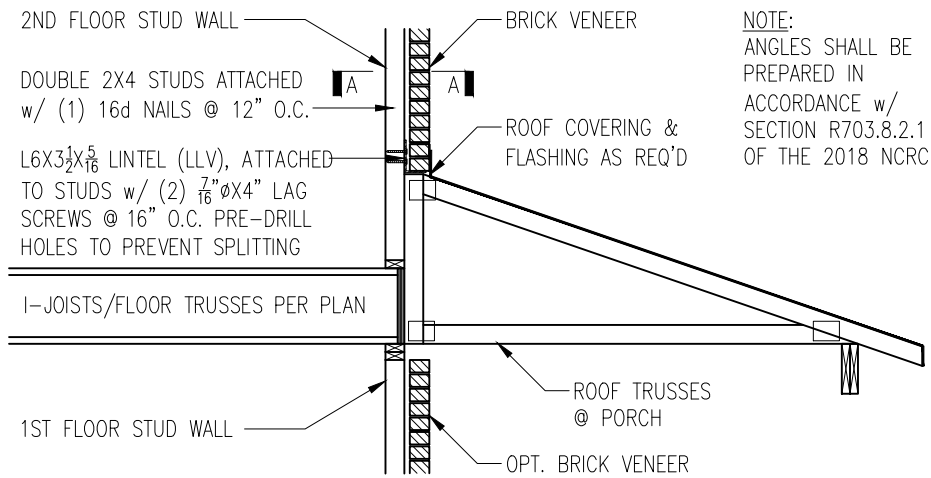

NOTE:
ANGLES SHALL BE
PREPARED IN
ACCORDANCE w/
SECTION R703.8.2.1
OF THE 2018 NCR

TRUSSES PERPENDICULAR TO STUD WALL

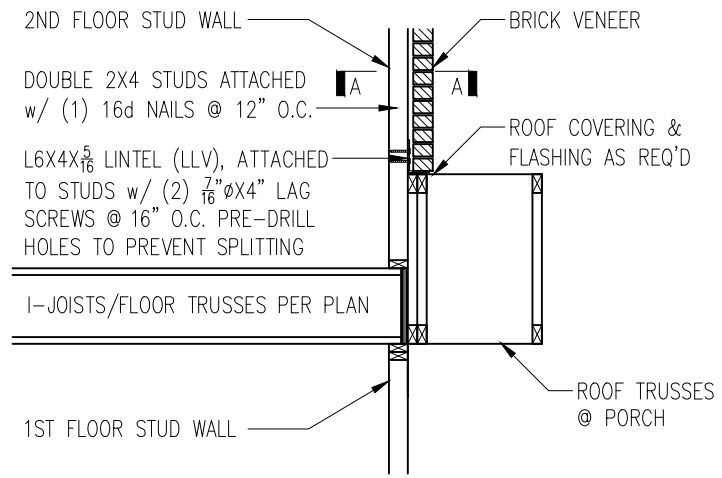

TRUSSES PARALLEL TO STUD WALL

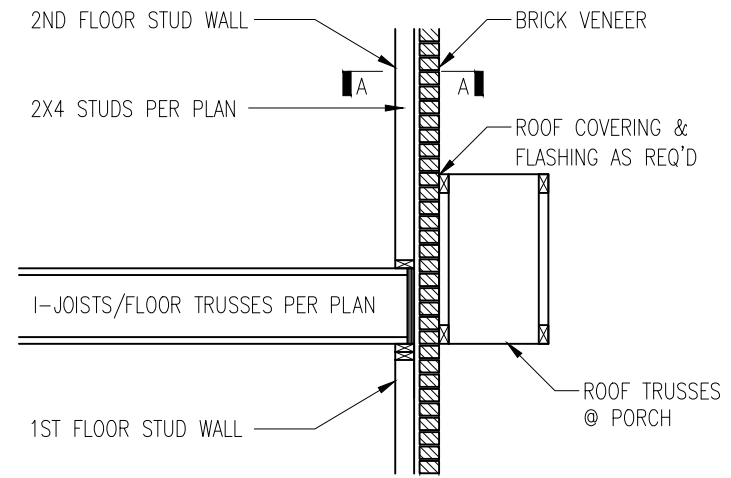

TRUSSES PARALLEL TO STUD WALL
w/ CONTINUOUS BRICK VENEER

1 BRICK SUPPORT ABOVE STORAGE/PORCH ROOF DETAIL
D4f NTS

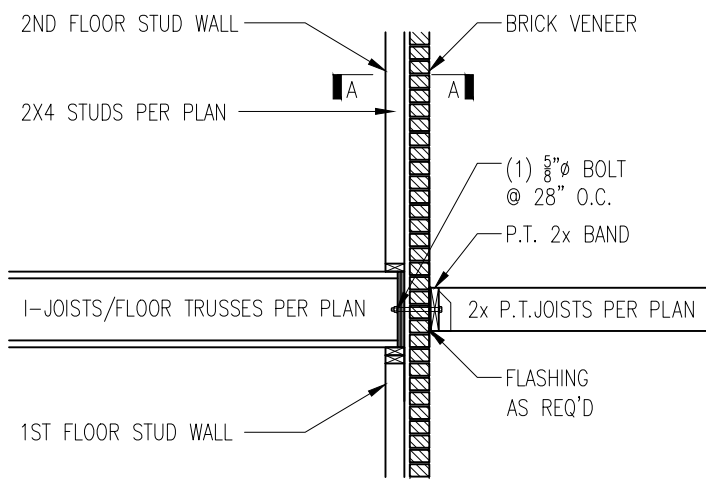

3 BALCONY JOIST ATTACHMENT
D4f NTS

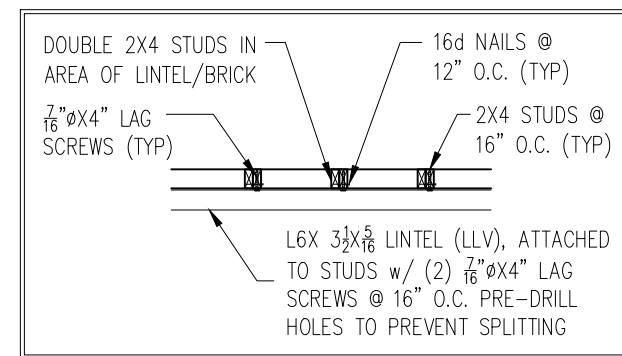

SECTION A-A
NTS

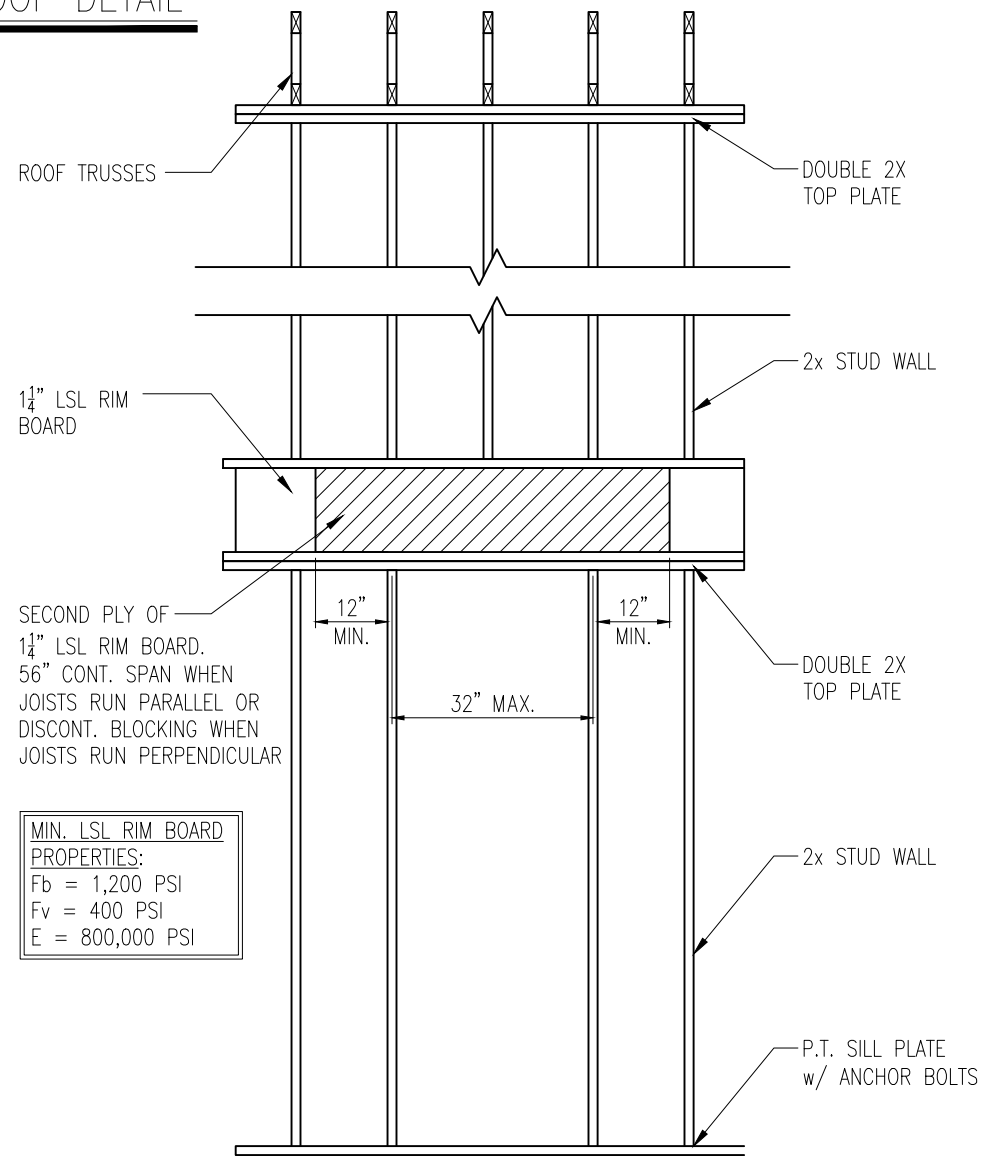

MIN. LSL RIM BOARD
PROPERTIES:
Fb = 1,200 PSI
Fv = 400 PSI
E = 800,000 PSI

4 TYP. RANGE VENT FRAMING
D4f NTS

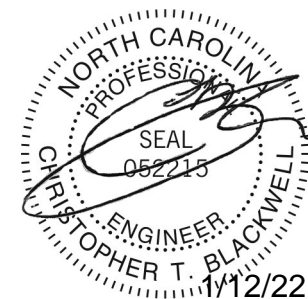

STRUCTURAL MEMBERS ONLY

SUMMIT
ENGINEERING LABORATORY TESTING
3070 HAMMOND BUSINESS
PLACE, SUITE 171
RALEIGH, NC 27603
OFFICE: 919.380.9991
FAX: 919.380.9993
WWW.SUMMIT-COMPANIES.COM

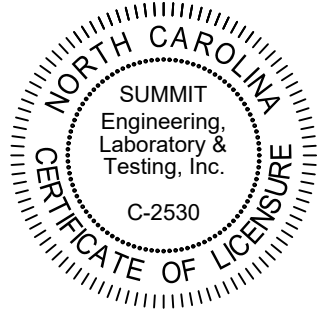

PROJECT
Standard Details
Framing Details - Bracing
CLIENT
LGI Homes
3037 Sherman Drive
Lancaster, SC 29720

CURRENT DRAWING
DATE: 10/05/21
SCALE: NTS
PROJECT #: 3554.T0040
DRAWN BY: MSB
CHECKED BY: CTB

ORIGINAL DRAWING
DATE: 10/01/19 PROJECT #: 24512

REFER TO COVER SHEET FOR A
COMPLETE LIST OF REVISIONS

SHEET
D4f

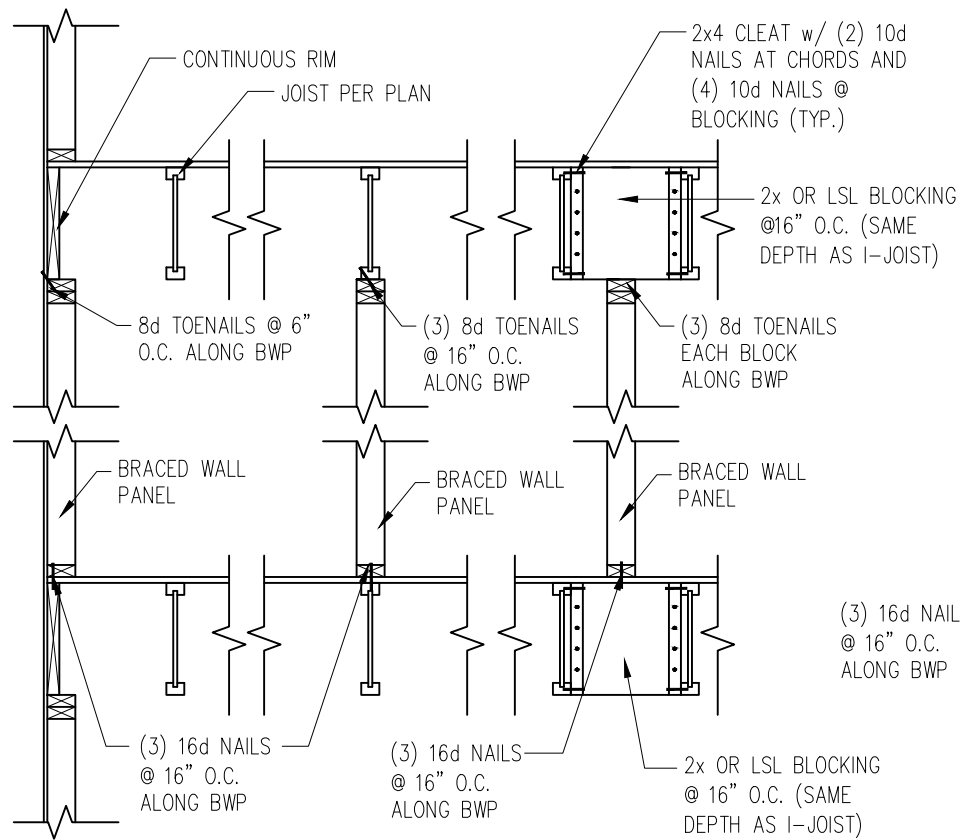

JOISTS PARALLEL TO BRACED WALLS

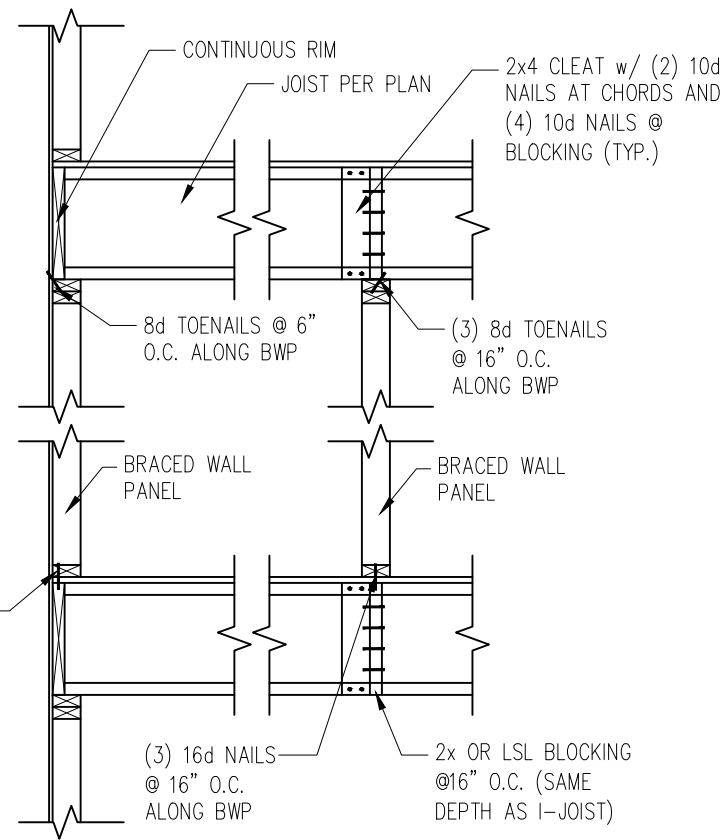

JOISTS PERPENDICULAR TO BRACED WALLS

1 TYP. WALL PANEL TO FLOOR/CEILING CONNECTION
D5f 1" = 1'-0"

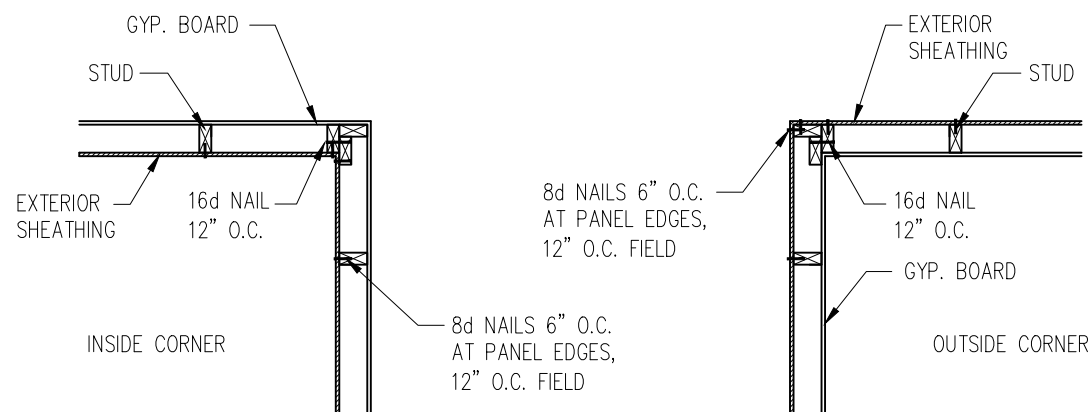

2 TYP. EXTERIOR CORNER FRAMING
D5f 1" = 1'-0"

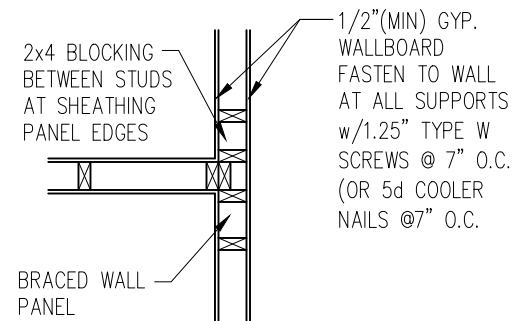

3 INTERIOR 3-STUD WALL INTERSECTION
D5f 1" = 1'-0"

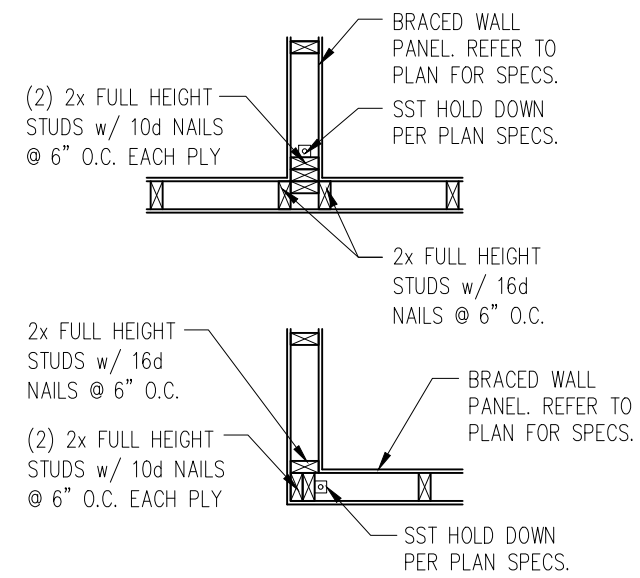

4 TYP. HOLD DOWN DETAIL
D5f 1" = 1'-0"

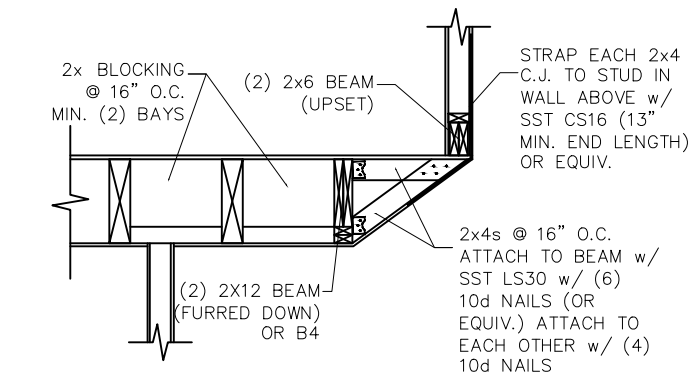

1 FRAMING OVER STAIRS
S3.0

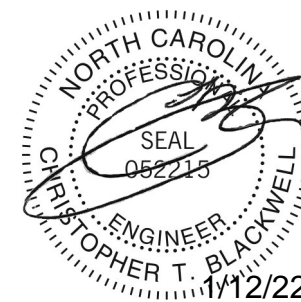

STRUCTURAL MEMBERS ONLY

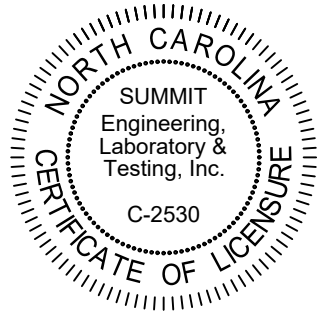

PROJECT
Standard Details
Framing Details - Bracing
CLIENT
LGI Homes
3037 Sherman Drive
Lancaster, SC 29720

CURRENT DRAWING
DATE: 10/05/21
SCALE: NTS
PROJECT #: 3554.T0040
DRAWN BY: MSB
CHECKED BY: CTB

ORIGINAL DRAWING
DATE: 10/01/19 PROJECT #: 24512

REFER TO COVER SHEET FOR A COMPLETE LIST OF REVISIONS

SHEET

D5f

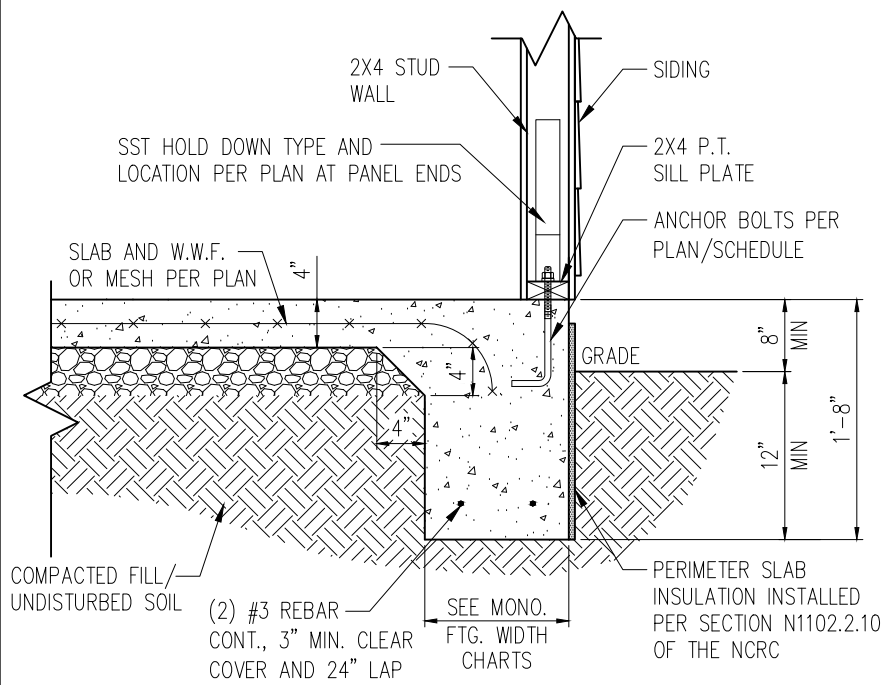

1 SLAB DETAIL w/ HOLD-DOWN
D6f 3/4" = 1'-0"

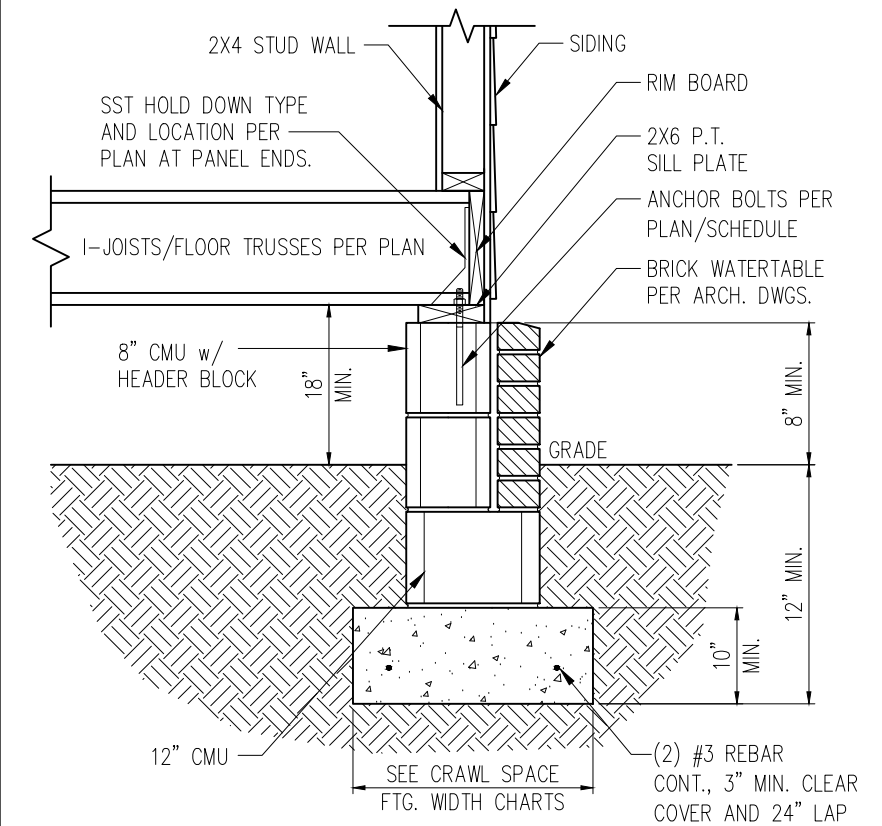

2 CRAWL FOUNDATION WALL DETAIL W/ H-D
D6f 3/4" = 1'-0"

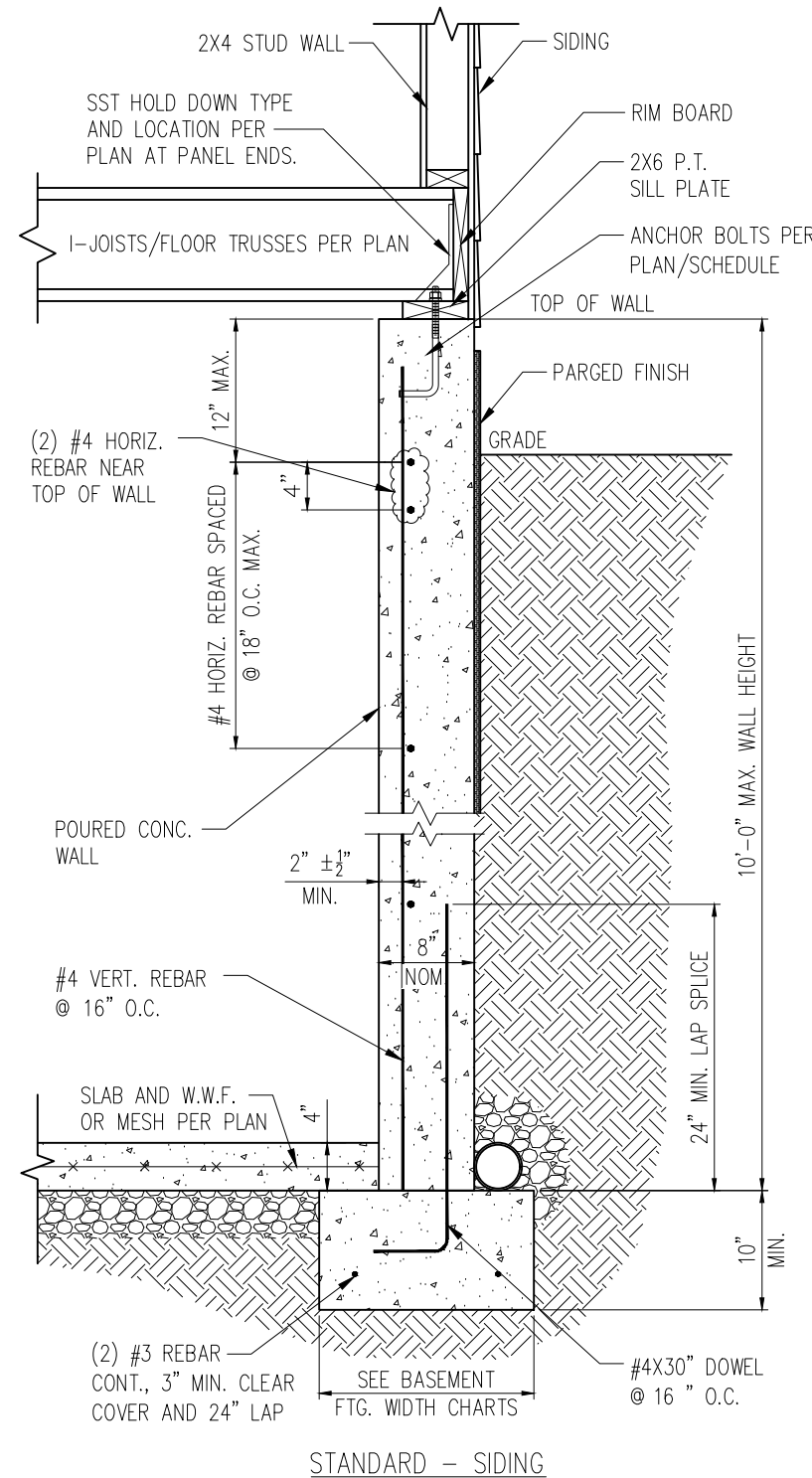

3 BASEMENT FOUNDATION WALL DETAIL W/ HOLD-DOWN
D6f 3/4" = 1'-0"

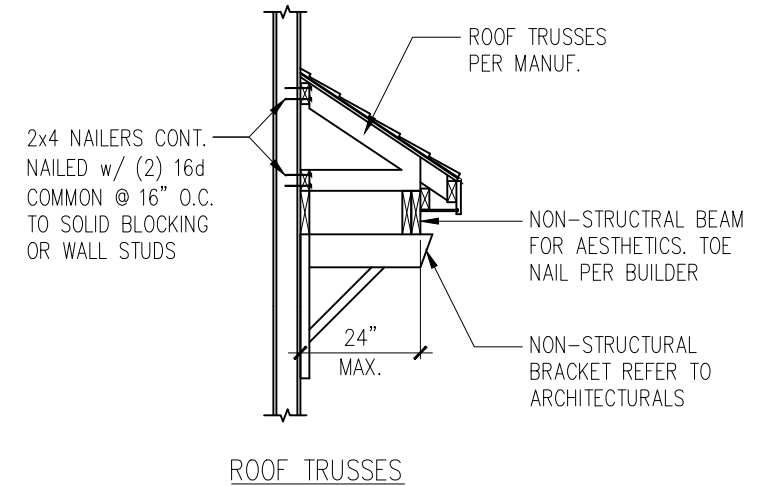
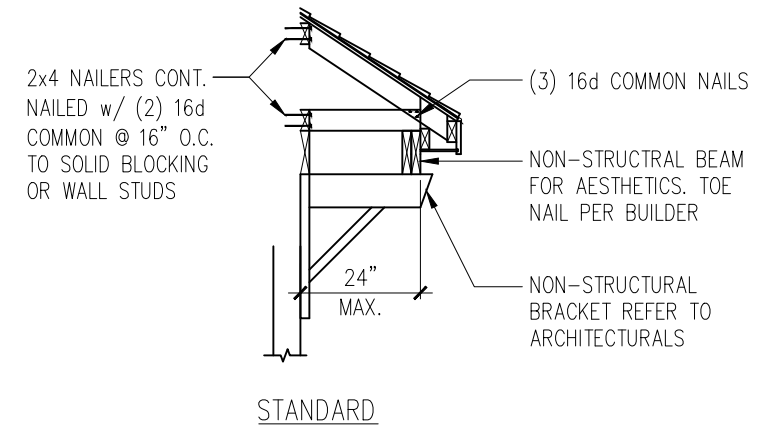

4 GABLE ROOF RETURN
D6f N.T.S.

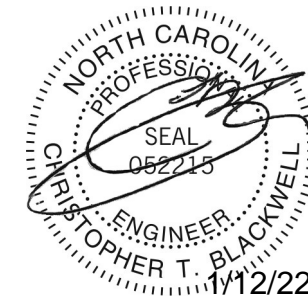

STRUCTURAL MEMBERS ONLY

SUMMIT
ENGINEERING LABORATORY TESTING
3070 HAMMOND BUSINESS PLACE, SUITE 171
RALEIGH, NC 27603
OFFICE: 919.380.9991
FAX: 919.380.9993
WWW.SUMMIT-COMPANIES.COM

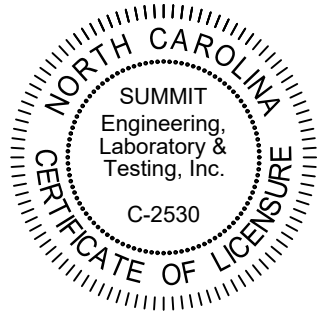

PROJECT
Standard Details
Framing Details - Bracing
CLIENT
LGI Homes
3037 Sherman Drive
Lancaster, SC 29720

CURRENT DRAWING
DATE: 10/05/21
SCALE: NTS
PROJECT #: 3554.T0040
DRAWN BY: MSB
CHECKED BY: CTB

ORIGINAL DRAWING
DATE: 10/01/19 PROJECT #: 24512

REFER TO COVER SHEET FOR A COMPLETE LIST OF REVISIONS

SHEET

D6f

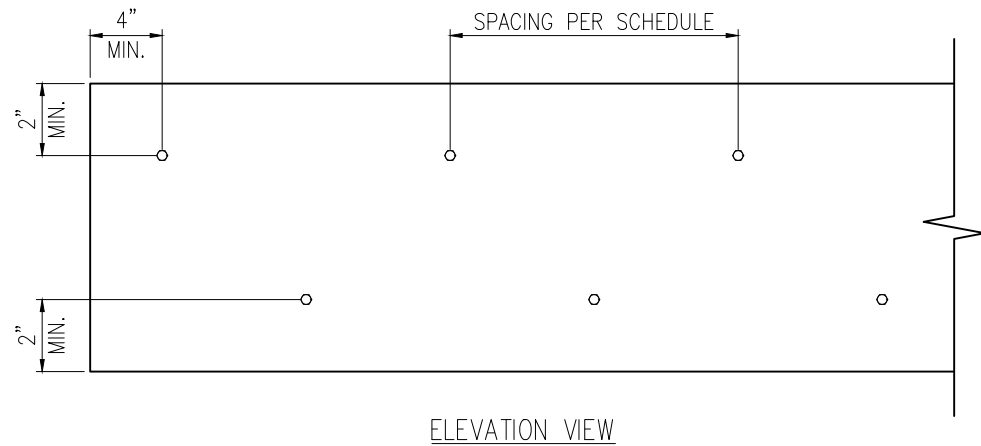

1 MULTI-PLY BEAM CONNECTION DETAIL
D7f N.T.S

MINIMUM FASTENING REQUIREMENTS FOR TOP- AND SIDE-LOADED MEMBERS

FASTENER TYPE	LVL DEPTH	3 1/2" WIDE		5 1/2" WIDE		7" WIDE	
		2-Ply 1 3/4"	3-Ply 1 3/4"	1 3/4" + 3 1/2"	4-Ply 1 3/4"	2-Ply 1 3/4" + 3 1/2"	2-Ply 3 1/2"
10d (0.128" x 3") Nails	7/4" ≤ d < 14"	3 rows @ 12" o.c.	3 rows @ 12" o.c. (ES)	3 rows @ 12" o.c.	-	3 rows @ 12" o.c. (ES)	-
	d ≥ 14"	4 rows @ 12" o.c.	4 rows @ 12" o.c. (ES)	4 rows @ 12" o.c.	-	4 rows @ 12" o.c. (ES)	-
16d (0.162" x 3 1/2") Nails	7/4" ≤ d < 14"	2 rows @ 12" o.c.	2 rows @ 12" o.c. (ES)	2 rows @ 12" o.c.	-	2 rows @ 12" o.c. (ES)	-
	d ≥ 14"	3 rows @ 12" o.c.	3 rows @ 12" o.c. (ES)	3 rows @ 12" o.c.	-	3 rows @ 12" o.c. (ES)	-
1/2" Through Bolts	d ≥ 7/4"	2 rows @ 24" o.c.		2 rows @ 24" o.c.		2 rows @ 24" o.c.	
SDS 1/4" x 3 1/2", WS35, 3 3/8" TrussLok		2 rows @ 24" o.c.	2 rows @ 24" o.c. (ES)	2 rows @ 24" o.c.	-	2 rows @ 24" o.c. (ES)	-
SDS 1/4" x 6", WS6		-	-	-	2 rows @ 24" o.c. (ES)		-
5" TrussLok		-	2 rows @ 24" o.c.		-		-
6 3/4" TrussLok		-	-		2 rows @ 24" o.c.		-

NOTES:

- All fasteners must meet the minimum requirements in the table above. Side-loaded multiple-ply members must meet the minimum fastening and side-loading capacity requirements given on page 48.
- Minimum fastening requirements for depths less than 7/4" require special consideration. Please contact your technical representative.
- Three general rules for staggering or offsetting for a certain fastener schedule:
 - if staggering or offsetting is not referenced, then none is required;
 - if staggering is referenced, then fasteners installed in adjacent rows on the front side are to be staggered up to one-half the o.c. spacing, but maintaining the fastener clearances above; and
 - if "ES" is referenced, then the fastener schedule must be repeated on each side, with the fasteners on the back side offset up to one-half the o.c. spacing of the front side (whether or not it is staggered).

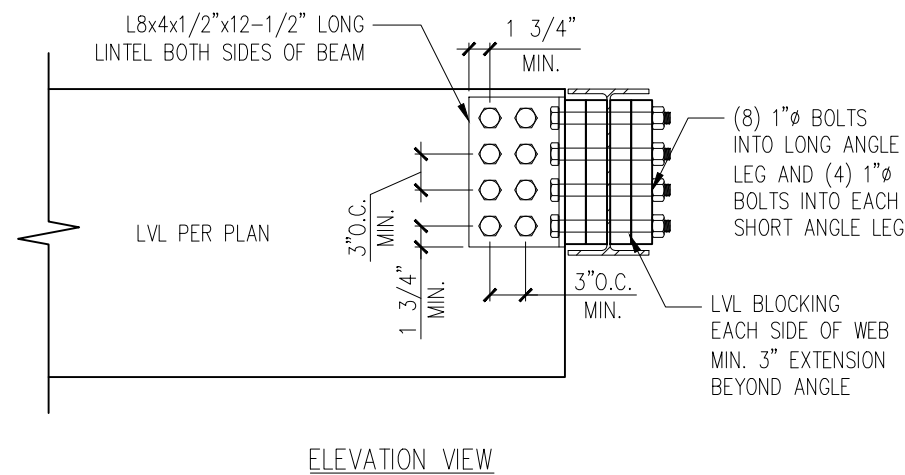
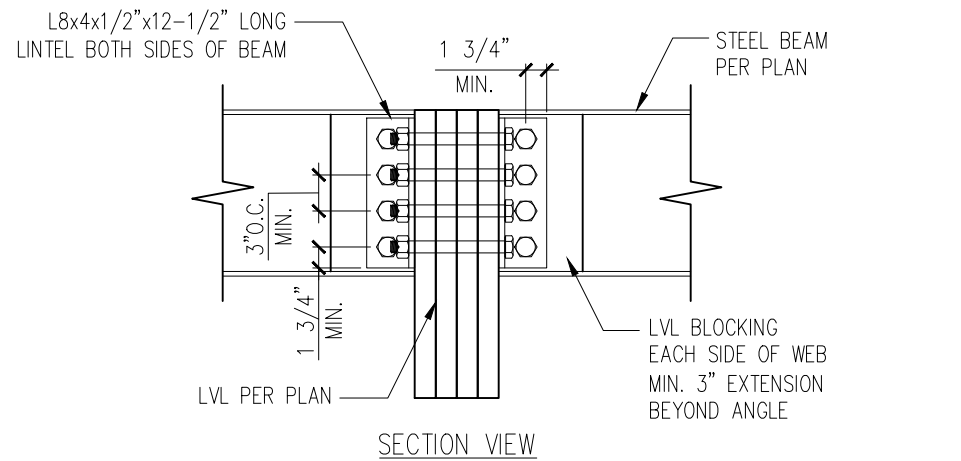

2 LVL TO STEEL DETAIL
D7f N.T.S

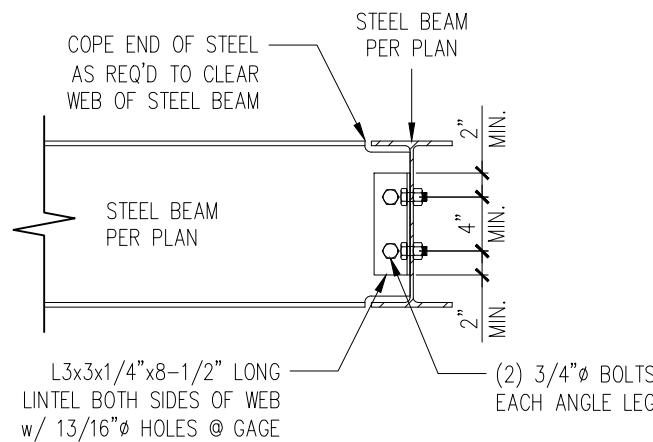
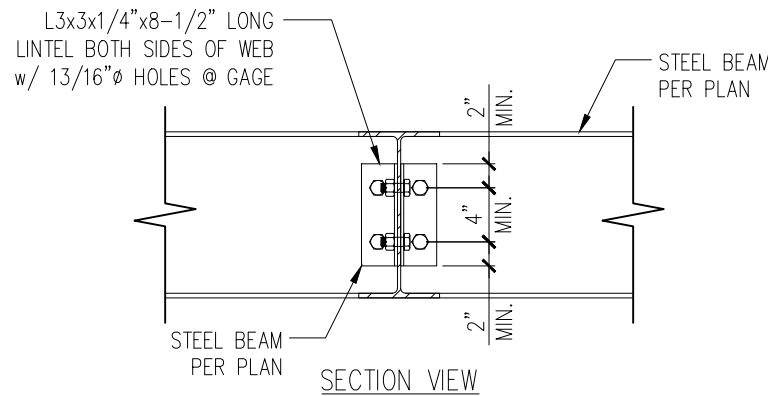

3 STEEL TO STEEL DETAIL
D7f N.T.S

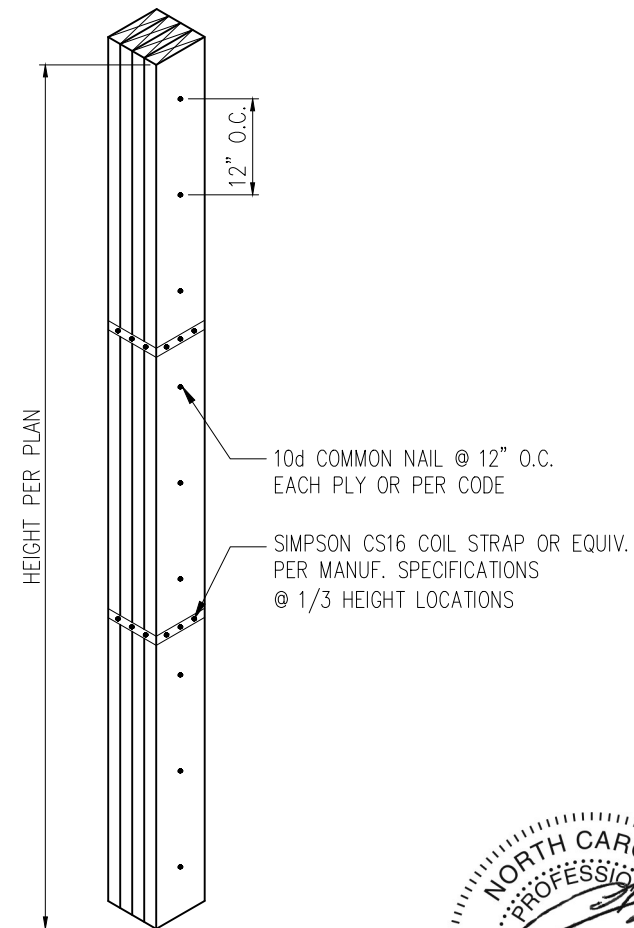

4 MULTI-PLY STUD CONNECTION DETAIL
D7f N.T.S 4+ PLYS

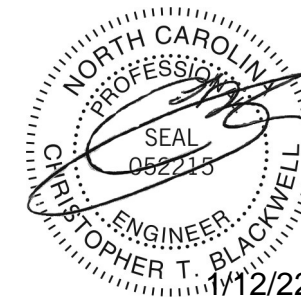

STRUCTURAL MEMBERS ONLY

SUMMIT
ENGINEERING LABORATORY TESTING
3070 HAMMOND BUSINESS PLACE, SUITE 171
RALEIGH, NC 27603
OFFICE: 919.380.9991
FAX: 919.380.9993
WWW.SUMMIT-COMPANIES.COM

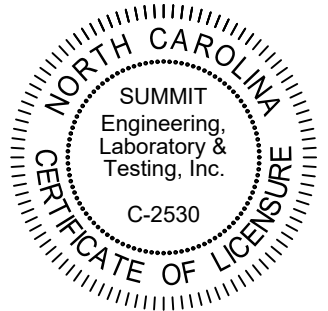

PROJECT
Standard Details
Framing Details - Bracing
CLIENT
LGI Homes
3037 Sherman Drive
Lancaster, SC 29720

CURRENT DRAWING
DATE: 10/05/21
SCALE: NTS
PROJECT #: 3554.T0040
DRAWN BY: MSB
CHECKED BY: CTB

ORIGINAL DRAWING
DATE: 10/01/19 PROJECT #: 24512

REFER TO COVER SHEET FOR A COMPLETE LIST OF REVISIONS

SHEET
D7f

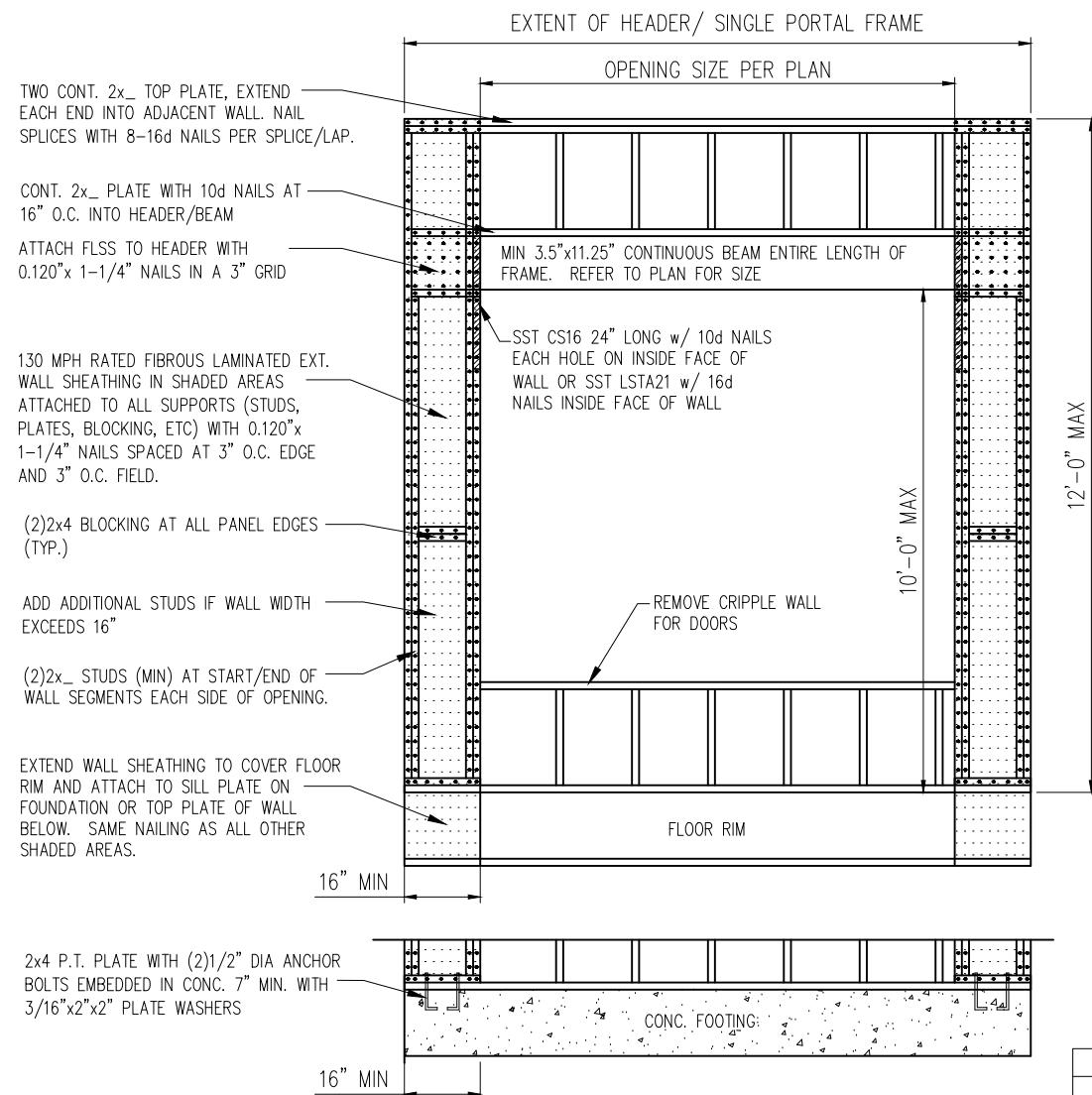

1 METHOD PF: PORTAL FRAME DETAIL
D8f NTS

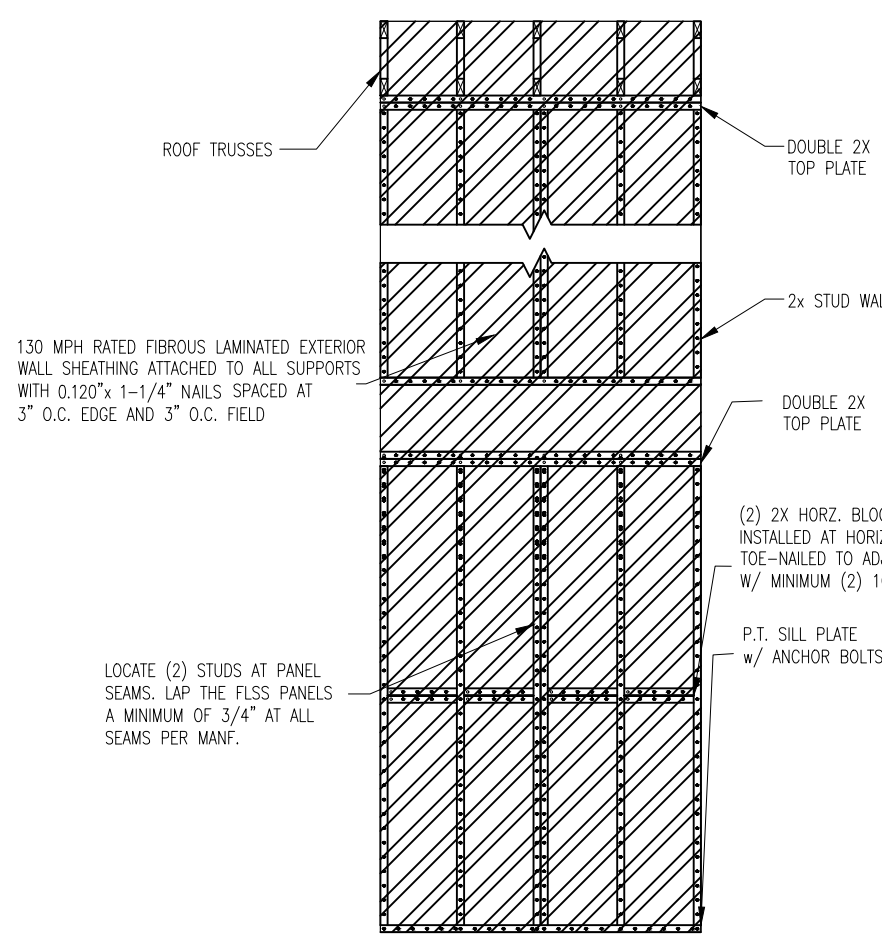

2 TYP. WALL BRACING
D8f NTS

ALLOWED FIBROUS LAMINATED STRUCTURAL SHEATHING (FLSS) for PORTAL FRAMES					
BRAND	MATERIAL	PRODUCT	REQUIRED CONNECTION		TECHNICAL EVALUATION REPORT*
			• PANEL EDGES	• INTERMEDIATE SUPPORTS	
OX ENGINEERED PRODUCTS, LLC	FIBROUS LAMINATED STRUCTURAL SHEATHING	THERMOPLY RED	3/8\"/>		

*BASED ON TECHNICAL EVALUATION REPORT FROM DJJ ENGINEERING, LLC

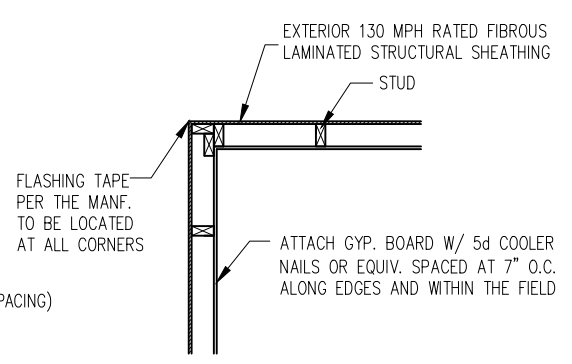

3 TYP. EXTERIOR CORNER FRAMING
D8f NTS

NOTES:
 -BRACED WALLS SHALL BE INSTALLED PER THE LENGTHS SHOWN ON THE SEALED PLANS.
 -16 GA. STAPLES MAY BE SUBSTITUTED WITH 0.120"x 1-1/4" NAILS OR 11 GAUGE 1-1/4-INCH LENGTH NAILS.
 -STAPLE CROWNS SHALL BE INSTALLED PARALLEL TO FRAMING.
 -WHERE 3/4" OVERLAP IS NOT INSTALLED, CONTRACTOR MAY COVER SEAM WITH 5" BUTYL FLASHING TAPE.
 -FLASH WINDOWS AND DOORS PER MANF.
 -LAP SIDING, STONE/BRICK VENEER, AND STUCCO MAY ALL BE INSTALLED FOR EXTERIOR CLADDING PROVIDED THAT THE FLSS MANUFACTURER'S INSTRUCTIONS ARE FOLLOWED AT THE TIME OF INSTALLATION.
 -SPRUCE-PINE-FIR AND SOUTHERN YELLOW PINE MAY BE USED. CONTRACTOR SHALL VERIFY THE SPECIES OF WOOD REFERENCED ON THE APPROVED PLANS.
 -THE DETAILS ABOVE ARE LIMITED TO 130 MPH WIND ZONES WIND EXPOSURE C

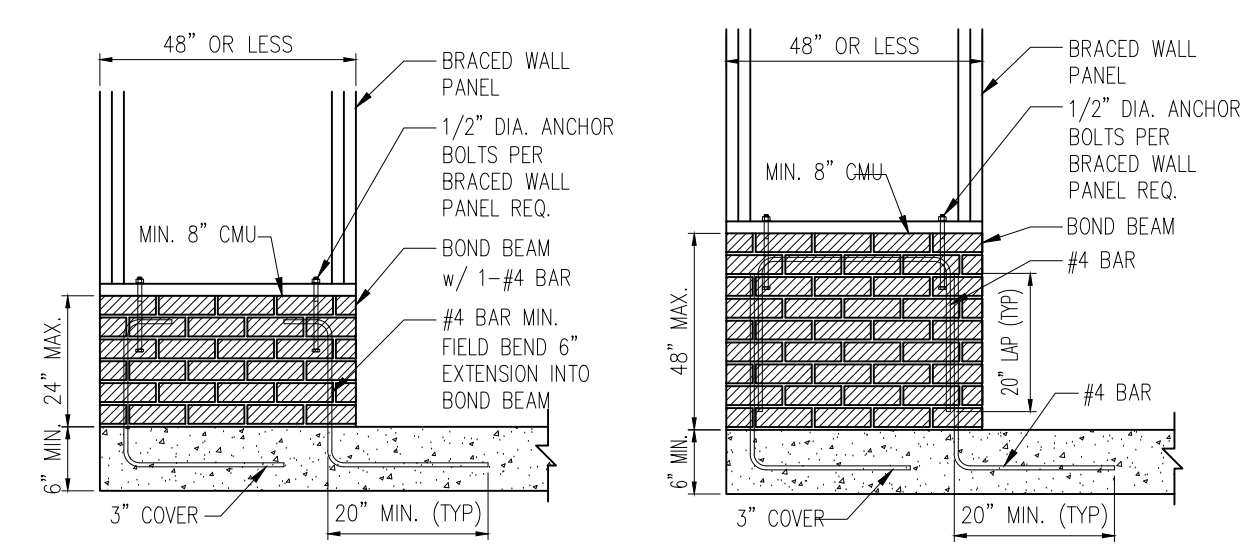

4 MASONRY STEM WALLS SUPPORTING BRACED WALL PANELS
D7f NTS

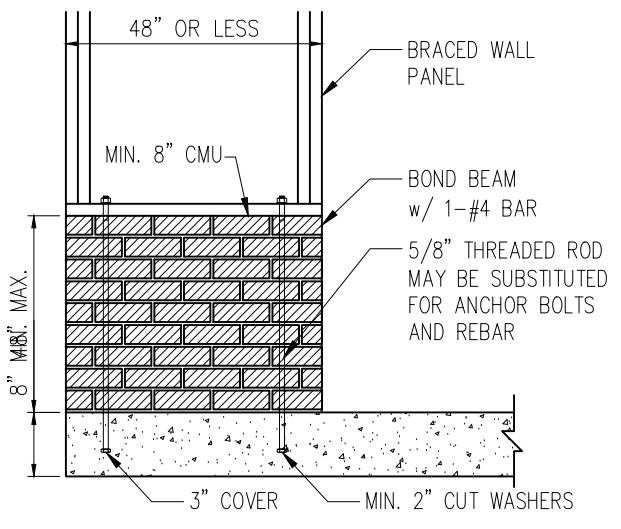

NOTE: GROUT BOND BEAMS AND ALL CELLS WHICH CONTAIN REBAR, THREADED RODS AND ANCHOR BOLTS

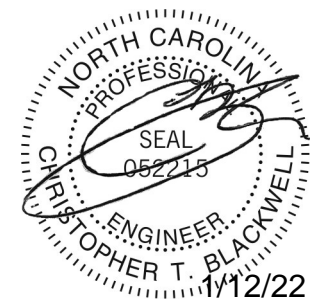
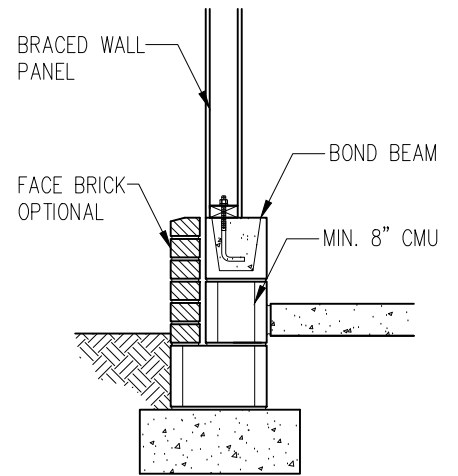

STRUCTURAL MEMBERS ONLY

SUMMIT
 ENGINEERING LABORATORY TESTING
 3070 HAMMOND BUSINESS PLACE, SUITE 171
 RALEIGH, NC 27603
 OFFICE: 919.380.9991
 FAX: 919.380.9993
 WWW.SUMMIT-COMPANIES.COM

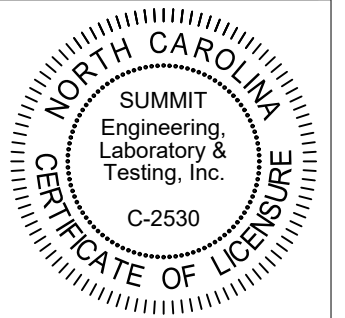

PROJECT
Standard Details
Framing Details - Bracing
 CLIENT
LGI Homes
3037 Sherman Drive
Lancaster, SC 29720

CURRENT DRAWING
 DATE: 10/05/21
 SCALE: NTS
 PROJECT #: 3554.T0040
 DRAWN BY: MSB
 CHECKED BY: CTB

ORIGINAL DRAWING
 DATE: 10/01/19
 PROJECT #: 24512

REFER TO COVER SHEET FOR A COMPLETE LIST OF REVISIONS

SHEET
D8f